

OSCER State of the Center

Henry Neeman, Director

**OU Supercomputing Center for Education & Research
A Division of OU Information Technology**

hneeman@ou.edu

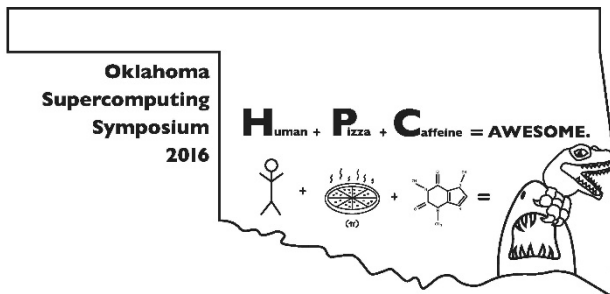

Wednesday September 21 2016
University of Oklahoma



Use Our Ugly Symposium Website!

Our ugly Symposium website

<http://symposium2016.oscer.ou.edu/>

has pretty complete agenda and speaker information, and is so ugly that it's actually reasonably optimized for handhelds like phones and tablets.

We encourage you to use it!



OSCAR State of the Center Address
Wed Sep 21 2016



Preregistration Profile 2016

- **Organizations**: 82 preregistered (or speaking)
 - **Academic**: preregistered 32 institutions in 13 states (AR,IL,IN,KS,MA,MO,NE,OH,OK,TN,TX,VA,WA)
 - Includes 18 institutions in 4 EPSCoR states (AR,KS,NE,OK)
 - **Industry**: preregistered 32 private companies
 - **Government**: preregistered 11 agencies (federal, state)
 - **Non-governmental**: preregistered 7 organizations
- **Demographics**: 338 preregistered (and/or speaking)
 - 28% OU, 72% non-OU (or unknown)
 - 62% Oklahoma, 38% non-Oklahoma (or unknown)
 - 70% from EPSCoR states, 30% non-EPSCoR (or unknown)
 - 69% academic, 31% non-academic (or unknown)



Attendee Profile 2002-2015

- Over 3300 attendees at the previous 14 Symposia
 - 69 in 2002, 225-325 per year thereafter, usually 275±25
- Organizations: 312 through 2014
 - **Academic**: from 116 institutions in 27 US states & territories
 - 64 institutions in 12 EPSCoR jurisdictions
 - 33 institutions in Oklahoma
 - PhD-granting, masters-granting, bachelors-granting, community colleges, career techs, high school
 - Historically Black University, Tribal College, 3 Native American Serving Non-tribal Institutions
 - public, private, for-profit
 - **Industry**: attendees from 147 firms
 - **Government**: attendees from 35 agencies (federal, state, municipal, foreign)
 - **Non-governmental/nonprofit**: attendees from 20 organizations



OSCER State of the Center Address
Wed Sep 21 2016



Symposium 2016 Sponsors: Thank You!

- Academic sponsor (1)
 - Great Plains Network
- Industry sponsors (16)
 - Platinum/Lunch (1): Hewlett-Packard Enterprise
 - Gold (1): Dell EMC
 - Silver (10): DDN Storage, Dell EMC, Intel, Lenovo, Lumentate/Brocade, Mellanox Technologies, Quantum, SGI, Spectra Logic/**Advanced Systems Group**
 - Bronze (4): Adaptive Computing, Advanced Clustering Technologies, NVIDIA, Penguin

Thank you all! Without you, the Symposium couldn't happen. Over the past 14 Symposia, we've had a total of 85 companies as sponsors – and just over half have repeated (or were acquired by/merged with other sponsors).



OSCER State of the Center Address
Wed Sep 21 2016



Thanks!

- OU IT
 - OU CIO/VPIT Loretta Early
 - Symposium committee: Dana Brunson (OSU), Debi Gentis (OU)
 - Symposium coordinator: Debi Gentis
 - Sponsorship coordinator: Chance Grubb
 - OSCER Operations Team: Dave Akin, Patrick Calhoun, Kali McLennan, Jason Speckman, Brett Zimmerman
 - All of the OU IT folks who helped put this together
- CCE Forum
 - Jake Maurer, Kristin Livingston
 - The whole Forum crew who helped put this together



OSCER State of the Center Address
Wed Sep 21 2016



Thanks: Plenary Speakers

- Dan Stanzione, Texas Advanced Computing Center, University of Texas at Austin
- Suresh Marru, Indiana University (lightning talk)
- Vas Vasiliadis, Globus/University of Chicago
- Stephen Wheat, Hewlett-Packard Enterprise (Platinum/Lunch sponsor)



OSCER State of the Center Address
Wed Sep 21 2016



Thanks: Gold Sponsor Speaker

- Nishanth Dandapanthula, Dell Technologies



OSCER State of the Center Address
Wed Sep 21 2016



Thanks: Breakout Speakers

1. Marcus A. Bond, Southeast Missouri State University
2. Dana Brunson, Oklahoma State University
3. Shane Corder, Children's Mercy Kansas City
4. Nishanth Dandapanthula, Dell Technologies
5. Brady Deetz, Laureate Institute for Brain Research
6. Karl Frinkle, Southeastern Oklahoma State University
7. Kyle Hutson, Kansas State University
8. Mark Laufersweiler, University of Oklahoma
9. Evan Lemley, University of Central Oklahoma
10. Suresh Marru, Indiana University
11. Perdeep K. Mehta, The Samuel Roberts Noble Foundation
12. Mike Morris, Southeastern Oklahoma State University
13. Horst Severini, University of Oklahoma
14. Nathan Sloat, University of Oklahoma
15. Neal N. Xiong, Southwestern Oklahoma State University



OSCER State of the Center Address
Wed Sep 21 2016



Thanks!

To all of you for participating, and to those many of you who've shown us so much loyalty over the past 14 years.



OSCER State of the Center Address
Wed Sep 21 2016



Outline

- OU
 - Resources
 - Accomplishments
- OCII/OneOCII



OSCER State of the Center Address
Wed Sep 21 2016



Resources



Dell Intel Haswell HPC Cluster

1000 Intel Xeon “Haswell” CPU chips

Photo: Jawanza Bassue

10,180 CPU cores

~23 TB RAM

~360 TB global disk

Mellanox FDR10 Infiniband
(13.33 Gbps, ~1 microsec latency)

Dell N-series Gigabit/10G Ethernet

CentOS 7

Peak speed: 347 TFLOPs*

*TFLOPs: trillion calculations per second

30% of the nodes are

“condominium” (owned by
individual research teams).

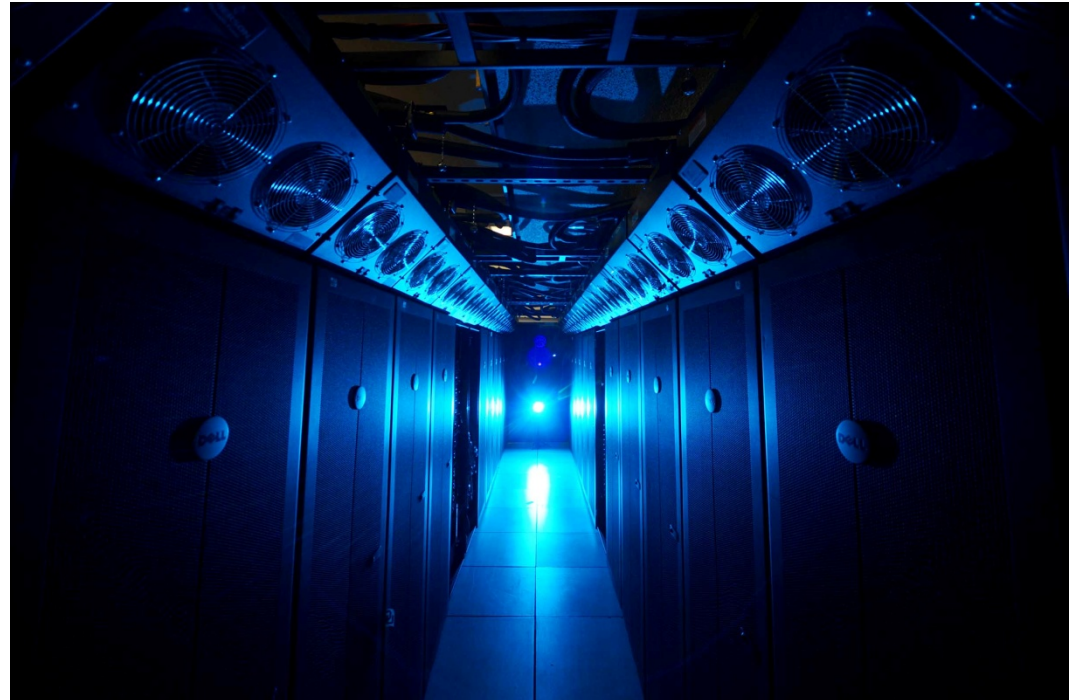

schooner.oscer.ou.edu



OSCER State of the Center Address
Wed Sep 21 2016



Schooner: non-condominium nodes

- Compute nodes, non-condominium
 - 266 x R430, dual E5-2650v3 10-core 2.3 GHz, 32 GB RAM
 - 46 x R430, dual E5-2670v3 12-core 2.3 GHz, 64 GB RAM
- Accelerator-capable nodes, non-condominium
 - 28 x R730, dual E5-2650v3 10-core 2.3 GHz, 32 GB RAM
 - 8 x R730, dual E5-2670v3 12-core 2.3 GHz, 64 GB RAM
- Large RAM node, non-condominium
 - 1 x R930, quad E7-4809v3 8-core 2.0 GHz, 1024 GB RAM
- Accelerators, non-condominium
 - 6 x NVIDIA K20M
 - 24 x Intel Xeon Phi 31S1P
- Subtotal peak CPU speed, non-condominium: 265.1 TFLOPs



Schooner: non-condominium other

- Interconnects
 - Infiniband: Mellanox FDR10 3:1 oversubscribed
 - Ethernet: GigE downlinks to nodes, 10GE uplinks to core
- Storage (user-accessible)
 - DataDirect Networks SFA7700X w/70 x 6 TB = ~300 TB useable
 - 6 x home/scratch 12 x 6 TB = ~291 TB useable



OSCER State of the Center Address
Wed Sep 21 2016



Schooner: Old Condominium

As an experiment, we're transferring condominium nodes from Boomer over to Schooner.

- Compute nodes, condominium, old
 - 73 x R620, dual E5-2650 (Sandy Bridge), oct core, 2.0 GHz
- Accelerator-capable nodes, condominium, old
 - 6 x R720, dual E5-2650, oct core, 2.0 GHz
- Accelerators, condominium, old
 - 12 x NVIDIA M2075
 - 6 x NVIDIA K20M
- Storage, diskfull nodes, condominium, old
 - 4 x R720xd, 12 x 3 TB = ~19 TB useable each
- Subtotal peak CPU speed, old condominium: 20.22 TFLOPs



Schooner: New Condominium

- Compute nodes, condominium, new
 - 6 x R430, dual E5-2650Lv3 12-core 1.8 GHz, 64 GB RAM
 - 39 x R430, dual E5-2670v3 12-core 2.3 GHz, 64 GB RAM
- Accelerator-capable nodes, condominium, new
 - 1 x R730, dual E5-2650v3 10-core 2.3 GHz, 32 GB RAM
 - 3 x R730, dual E5-2670v3 12-core 2.3 GHz, 64 GB RAM
- Accelerators
 - 8 x NVIDIA K20M
- Storage nodes, condominium, new
 - 1 x T630, 16 x 6 TB, 128 GB RAM, ~N TB useable each
 - 1 x T630, 16 x 8 TB, 128 GB RAM, ~N TB useable each
- Subtotal peak CPU speed, new condominium: 41.98 TFLOPs



Schooner: Peak Speed

- Subtotal peak CPU speed, non-condominium: 266.57 TFLOPs
- Subtotal peak CPU speed, old condominium: 20.22 TFLOPs
- Subtotal peak CPU speed, new condominium: 41.98 TFLOPs
- Total peak CPU speed, public + old condominium + new condominium: 328.78 TFLOPs
- Schooner will be ~3 times as fast as Boomer.
- Roughly 24% of Schooner's peak speed is condominium.

OURcloud

OU Research Cloud (virtualized server pool) Draft 4/23/2013

5 x GigE + 1 x iDRAC
per compute node
would fill the pair of
world-facing
PCT5548 switches.

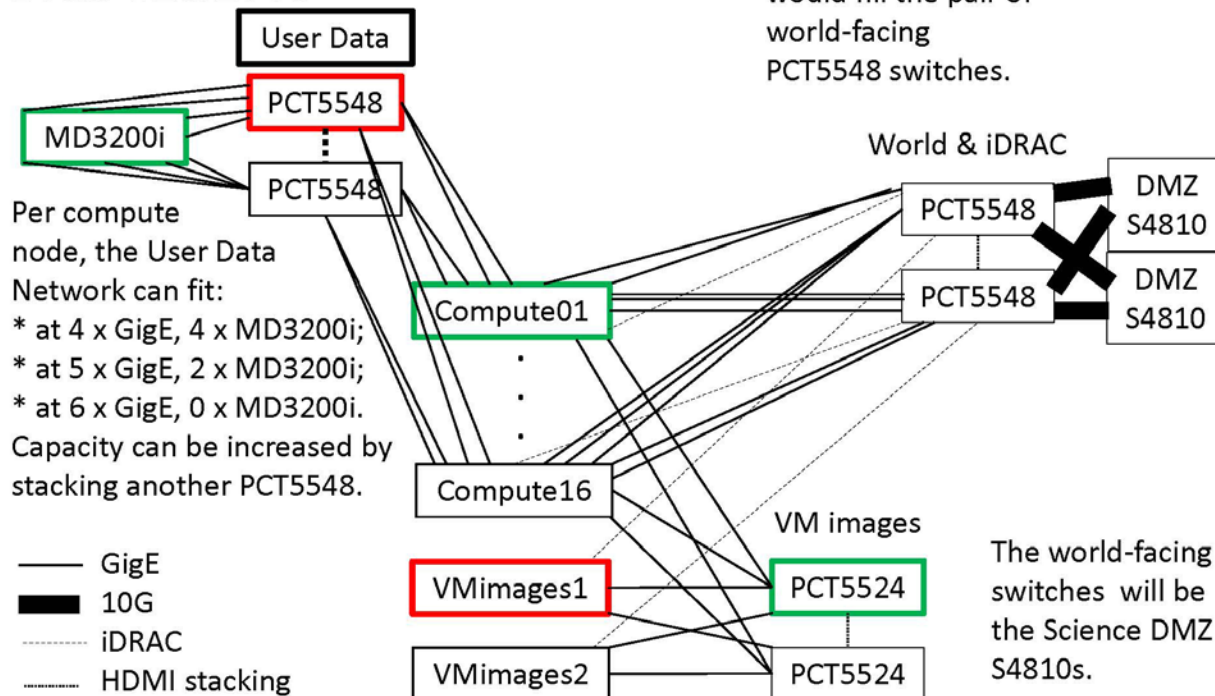

OURcloud



OSCER State of the Center Address
Wed Sep 21 2016



Oklahoma PetaStore

A mix of disk and tape, available to researchers at OU (and statewide), with a unique business model that makes long term archival storage affordable.



OSCER Personnel

- Director: Henry Neeman
- Senior System Administrators: David Akin, Brett Zimmerman
- Petascale Storage Administrator: Patrick Calhoun
- **System Administrators: Kali McLennan, Jason Speckman**
- Research IT Coordinator: Debi Gentis
- Associate Director for Remote & Heterogeneous Computing: Horst Severini



OSCER State of the Center Address
Wed Sep 21 2016

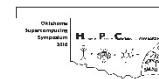

Accomplishments



OneOCII Outcomes: Research

- External research funding to OK institutions facilitated by OneOCII lead institutions (Fall 2001- Summer 2013): **\$200M+**
- Funded projects facilitated: **360+**
- OK faculty and staff: **200+** in **20+** academic disciplines
- Specifically needed OneOCII just to be funded: **~\$44M**
(necessary but far from sufficient)
 - NSF EPSCoR RII Track-1 (2008-13, OU+OSU): \$15M
 - NSF EPSCoR RII Track-1 (2013-18, OU+OSU+Noble): \$20M
 - NSF EPSCoR RII Track-2 (OU+OSU+KU+KSU): \$6M (\$3M to OU+OSU)
 - NSF EPSCoR RII C2 (OU+OSU+TU+LU+Noble+OneNet): \$1.17M
 - NSF CC-NIE (OU+OSU+LU+OII+UCO+OneNet): \$500K
 - NSF CC*IIE (OU): \$400K
 - NSF CC*IIE (OneNet+GPN): \$350K
 - NSF MRI (OU): \$793K
 - NSF MRI (OSU): \$908K
 - NSF MRI (OSU): \$950K
 - NSF MRI (Langston U): \$250K
 - NSF MRI (UCO): \$304K
 - NSF MRI (TU): \$180K
 - DOD DURIP (TU): \$200K
- Publications facilitated: **over 2000**



OSCER State of the Center Address
Wed Sep 21 2016



OneOCII Outcomes: Education

Teaching: 9 institutions including 3 MSIs

- Taught parallel computing using OneOCII resources:
 - Cameron U – multiple times
 - East Central U (NASNI)
 - Oklahoma City U – multiple times
- Taught parallel computing via LittleFe baby supercomputer and OneOCII resources:
 - Southeastern Oklahoma State U (NASNI) – 3 semester sequence, multiple times
- Taught computational chemistry using OneOCII resources:
 - Northeastern State U (NASNI) – multiple times
 - Southern Nazarene U
 - Rogers State U – multiple times
- Taught Bioinformatics using OneOCII resources:
 - U Tulsa – 2 semester sequence



OSCER State of the Center Address
Wed Sep 21 2016



OneOCII Outcomes: Resources

7 institutions including 2 MSIs, plus C2 institutions

- NSF Major Research Instrumentation grants: \$2.9M
 - OU: Oklahoma PetaStore, \$793K (in production)
 - Oklahoma State U: Cowboy cluster, \$909K (in production), Pistol Pete cluster, \$950K (new award)
 - Langston U: cluster, \$250K (in production)
 - U Central Oklahoma: cluster, \$304K (in production)
 - U Tulsa: clusters, \$180K + \$200K
- Defense University Research Instrumentation Program
 - U Tulsa: cluster, \$200K
- LittleFe baby supercomputer grants (\$2520 each)
 - OU: Ron Barnes
 - Oklahoma City U: Larry Sells & John Goulden
 - Southeastern Oklahoma State U: Mike Morris & Karl Frinkle
- Networking
 - NSF EPSCoR RII C2 grant: \$1.17M
 - NSF CC-NIE grant: \$500K
 - NSF CC*IIE grant: \$400K



OSCER State of the Center Address
Wed Sep 21 2016



OCII/OneOCII CI Grants

COMPLETED

1. Grant No. EPS-0919466, "A cyberCommons for Ecological Forecasting," OU+OSU+KU+KSU, \$6M, **COMPLETED**
2. Grant No. EPS-1006919, "Oklahoma Optical Initiative," OU+OSU+Noble+TU+LU+OneNet, \$1.17M, **COMPLETED**
3. Grant No. OCI-10310029, "MRI: Acquisition of Extensible Petascale Storage for Data Intensive Research," OU, \$793K
4. Grant No. OCI-1126330, "Acquisition of a High Performance Compute Cluster for Multidisciplinary Research," OSU, \$908K
5. Grant No. ACI- 1229107, "Acquisition of a High Performance Computing Cluster for Research and Education," LU, \$250

ONGOING

1. Grant No. ACI-1341028, "OneOklahoma Friction Free Network," OU+OSU+LU+OII+UCO+OneNet, \$500K
2. Grant No. ACI-1440783, "A Model for Advanced Cyberinfrastructure Research and Education Facilitators," OU, \$400K
3. Grant No. ACI-1440774, "ENCITE: ENabling CyberInfrastructure via Training and Engagement," OneNet+GPN, \$130K
4. Grant No. ACI-1429702, "MRI: Acquisition of a High Performance Computing Cluster for Research at a Predominantly Undergraduate Institution," UCO, \$304K -- **RECENT RIBBON CUTTING**
5. Grant No. ACI-1531128, "MRI: Acquisition of Shared High Performance Compute Cluster for Multidisciplinary Computational and Data-Intensive Research," OSU, \$950K
6. Grant No. ?, "DURIP-ARO: Heterogeneous Cluster for Cyber-Physical System Security Analytics," TU, \$200K
7. Grant No. CNS-1531270, "MRI: Development of Heterogeneous Cluster for Cyber-Physical System Hybrid Analytics," TU, \$180K

TOTAL to OK under OCII/OneOCII: Sep 2008-Apr 2016:

\$8.8M in 12 CI grants to 8 OK institutions (OU, OSU, TU, LU, UCO, OII, Noble, OneNet)

(average of \$1.25M per year in new CI grants to OK institutions)

Comparison: 2001-2008: \$722K (3 grants) TOTAL (1/12 as much)



OSCER State of the Center Address
Wed Sep 21 2016



Grants That Needed OCII/OneOCII

COMPLETED

- Grant No. EPS-0814361, “Building Oklahoma's Leadership Role in Cellulosic Bioenergy,” OU+OSU, \$15M

ONGOING

- Grant No. EPS-1301789, “Adapting Socio-ecological Systems to Increased Climate Variability,” OU+OSU+TU+Noble, \$20M

TOTAL under OCII/OneOCII: \$35M in 2 grants that needed OCII/OneOCII to be fundable, to 4 OK institutions since Sep 2008



OSCAR State of the Center Address
Wed Sep 21 2016



Papers About Pieces of OneOCII

1. S. P. Calhoun, D. Akin, B. Zimmerman and H. Neeman, 2016: “Large Scale Research Data Archiving: Training for an Inconvenient Technology.” *Journal of Computational Science*, to appear. DOI: [10.1016/j.jocs.2016.07.005](https://doi.org/10.1016/j.jocs.2016.07.005).
2. H. Neeman, A. Bergstrom, D. Brunson, C. Ganote, Z. Gray, B. Guilfoos, R. Kalescky, E. Lemley, B. G. Moore, S. K. Ramadugu, A. Romanella, J. Rush, A. H. Sherman, B. Stengel and D. Voss, 2016: “The Advanced Cyberinfrastructure Research and Education Facilitators Virtual Residency: Toward a National Cyberinfrastructure Workforce.” *Proc. XSEDE'16*, article 57. DOI: [10.1145/2949550.2949584](https://doi.org/10.1145/2949550.2949584).
3. H. Neeman, K. Adams, J. Alexander, D. Brunson, S. P. Calhoun, J. Deaton, F. Fondjo Fotou, K. Frinkle, Z. Gray, E. Lemley, G. Louthan, G. Monaco, M. Morris, J. Snow and B. Zimmerman, 2015: “On Fostering a Culture of Research Cyberinfrastructure Grant Proposals within a Community of Service Providers in an EPSCoR State.” *Proc. XSEDE'15*, article 19. DOI: [10.1145/2792745.2792764](https://doi.org/10.1145/2792745.2792764).
4. H. Neeman, D. Akin, J. Alexander, D. Brunson, S. P. Calhoun, J. Deaton, F. Fondjo Fotou, B. George, D. Gentis, Z. Gray, E. Huebsch, G. Louthan, M. Runion, J. Snow and B. Zimmerman, 2014: “The OneOklahoma Friction Free Network: Towards a Multi-Institutional Science DMZ in an EPSCoR State.” *Proc. XSEDE'14*, article 49. DOI: [10.1145/2616498.2616542](https://doi.org/10.1145/2616498.2616542).
5. S. P. Calhoun, D. Akin, J. Alexander, B. Zimmerman, F. Keller, B. George and H. Neeman, 2014: “The Oklahoma PetaStore: A Business Model for Big Data on a Small Budget.” *Proc. XSEDE'14*, article 48. DOI: [10.1145/2616498.2616548](https://doi.org/10.1145/2616498.2616548).
6. C. Carley, B. McKinney, L. Sells, C. Zhao and H. Neeman, 2013: “Using a Shared, Remote Cluster for Teaching HPC.” *Proc. IEEE CLUSTER 2013*. DOI: [10.1109/CLUSTER.2013.6702630](https://doi.org/10.1109/CLUSTER.2013.6702630).
7. H. Neeman, D. Brunson, J. Deaton, Z. Gray, E. Huebsch, D. Gentis and D. Horton, 2013: “The Oklahoma Cyberinfrastructure Initiative.” *Proc. XSEDE'13*, article 70. DOI: [10.1145/2484762.2484793](https://doi.org/10.1145/2484762.2484793).

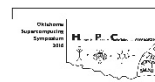

HPC Capacity

- 2002: 1.2 TFLOPs statewide, 1 Service Provider
- 2005: 6.5 TFLOPs statewide, 1 Service Provider
- 2008: 40 TFLOPs statewide, 2 Service Providers
- 2012: 200+ TFLOPs statewide, 4 Service Providers
- 2015: 400+ TFLOPs statewide, 5 Service Providers
- 2016: 400+ TFLOPs statewide, 6 Service Providers
- **2017: 500+ TFLOPs statewide, 6 Service Providers**



OSCER State of the Center Address
Wed Sep 21 2016



External Research Grants

1. R. Palmer, M. Yeary, "System and Software Engineering Support Services for CGI," CGI Federal, \$167K
2. M. Yeary, R. Palmer, "System and Software Engineering Support Services for CGI," CGI Federal, \$44K
3. M. Yeary, R. Palmer, "System and Software Engineering Support Services for CACI," CGI Federal Inc., \$99,908
4. R. Palmer, B. Cheong, C. Fulton, J. Salazar, H. Sigmarsson, M. Yeary, T. Yu, Y. Zhang, "," NOAA NSSL, \$2.51M
5. T. Yu, J. Salazar, C. Fulton, H. Bluestein, R. Palmer, B. Cheong, M. Biggerstaff, B. Isom, J. Kurdzo, R. Doviak, X. Wang, M. Yeary, "MRI: Development of C-band Mobile Polarimetric Imaging Radar," NSF, \$3.1M
6. R. Palmer, B. Cheong, C. Fulton, J. Salazar, H. Sigmarsson, M. Yeary, T. Yu, G. Zhang, Y. Zhang, "ARRC Demonstrator Development Activities for the MPAR Program: CPPAR and Horus," NOAA NSSL \$2.42M
7. R. Palmer, B. Cheong, "Electromagnetic Sensor Research & Development," Nanowave Technologies, \$1.5M
8. S. Wolff, J. Bottum, D Atkins, H. Neeman, "EAGER: Fact-Gathering and Planning for a National-Scale Cyberpractitioner Program," NSF, \$41K
9. G. Monaco et al, "The Role of Regional Organizations in Improving Access to the National Computational Infrastructure," NSF, \$50K
10. J. Towns et al, "XSEDE: eXtreme Science and Engineering Discovery Environment (supplement)," NSF \$3.7M
11. J. Bottum, M. Livny, H. Neeman, N. Tsinoremas, "RCN: Advancing Research and Education Through National Network of Campus Research Computing Infrastructures – The CaRC Consortium," NSF, \$748K
12. J. Towns et al, "XSEDE 2.0: Integrating, Enabling and Enhancing National Cyberinfrastructure with Expanding Community Involvement," NSF, \$110M
13. J. Neeman, J. Bottum, D. Atkins, D. Brunson, S. Wolff, "Cyberinfrastructure Leadership Academy," NSF, \$49K
14. F. Kong, M. Xue, "Technical Support to the Storm-Scale Numerical Weather Prediction Capability for Shenzhen Meteorological Bureau," Shenzhen Institute of Advanced Technology, Chinese Academy of Sciences, \$173K
15. B. Wawrik, Z. Yang, L. Atkinson, "Collaborative Research: Creatine Cycling in Marine Bacterial and Phytoplankton Assemblages," NSF, \$362K
16. E. Bridge, "Life history, kinship, and the evolution of alternative female reproductive strategies," \$3K
17. M. Biggerstaff;, "Optimizing radar guidance for triggered lightning," DARPA, \$200K

OSCER-FACILITATED FUNDING TO DATE:

\$447M total, \$205M to OU



OSCER State of the Center Address

Wed Sep 21 2016

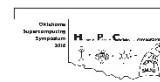

External Research Grants (cont'd)

18. C. Ziegler, M. Biggerstaff, M. Coniglio., "Measurement and analysis of nocturnal mesoscale convective systems and their stable boundary layer environment during PECAN," NSF,. \$583K
19. M. Biggerstaff, "Impact of cloud dynamics on chemical and electrical properties of storms observed during DC3," NSF, \$661K
20. K. Nicholas, "Deoxygenation and Reductive Coupling of Alcohols Catalyzed by Oxo-Metal Complexes," NSF. \$405K
21. S. Schroeder, N. Sloat, "Blue Water Student Internship Program," \$5K
22. S. Schroeder, "Protein and Metal Ion Binding in Viral RNA, HIV Accessory and Regulatory Complexes (HARC)," NIH, \$25K
23. L. Ding, "RII Track-2 FEC: Innovative, Broadly Accessible Tools for Brain Imaging, Decoding, and Modulation," NSF, \$6M
24. L. Ding, "Development of Imaging and EEG Biomarkers to Refine Neuromodulation Treatment Targets in MdDS," LIBR via NdDS, subaward PI, \$55K
25. L. Ding, "Development of the EEG Neuroergonomics Toolbox or EEGNT," FAA, \$243K
26. J. P. Shaffer, "Atom Surface Interactions and Hybrid Quantum Systems for Quantum Engineering Applications," AFOSR, \$750K
27. J. P. Shaffer, "High Sensitivity Absolute Electric Field Sensing with Atoms," National Reconnaissance Office, \$309K
28. J. P. Shaffer, "Control of Rydberg Interactions and Exotic States of Matter," NSF, \$472K
29. M. J. Wenger, "Building a unified theory methodology for identification of elementary cognitive systems," NSF, \$364K
30. B. Wang et al, "High Efficiency Flexible Dilute Nitrides Solar Cells for Space Applications," NASA EPSCoR, \$750K
31. D. LaDue, "REU Site: Real-World Research Experiences at the National Weather Center," NSF, \$885K
32. K. Marfurt, "3D Seismic Attribute Analysis using AASPI Prestack Technology," Korea Institute of Geoscience Mineral Resources, \$35K
33. B. Moore, "National Mesonet Program 2015-2016," Global Science Technology Inc, \$473K
34. S. Cavallo, "Multi-scale Predictability with a New Coupled Non-hydrostatic global model over the Arctic," DOD-ONR, \$273K

OSCER-FACILITATED FUNDING TO DATE:

\$447M total, \$205M to OU



OSCER State of the Center Address

Wed Sep 21 2016



External Research Grants (cont'd)

35. X. Chen, "Multi-scale validation of earthquake source parameters to resolve any spatial, temporal or magnitude-dependent variability at Parkfield, CA," NSF, \$224K
36. J. Ruyle, "Electrically Small Antenna Design Tool," U.S. Federal Govt, \$110K
37. J. Ruyle, "Two-Dimensionality for Conformal Multi-Platform Use," DARPA, \$499K
38. X. Wang, "Ensemble Kalman Filter and Hybrid Data Assimilation for Convective-Scale," \$73K
39. X. Wang, "Developing and Evaluating GSI-based EnKF-Variational Hybrid Data Assimilation for NCEP NAMRR to Improve Convection-Allowing Hazardous Weather Forecast," NOAA, \$123K
40. X. Wang, "Hybrid Data Assimilation for Convective-Scale," NOAA, \$99K
41. X. Wang, "Improving Global and Hurricane Prediction b Using Minimum-Cost Large Ensemble in GFS 4DVar Hybrid Data Assimilation System," NOAA, \$389K
42. X. Wang, "Tzero Revolution," Weathernews Americas, Inc., \$59K
43. X. Wang, "Improving the Understanding and Prediction of Nocturnal Convection through Advance Data Assimilation and Ensemble Simulation in PECAN," NSF, \$602K
44. J. Dyer, "Heart Rate Variability Assessment as an Indicator of Health," OUHSC, \$121K
45. M. Zaman, "Southern Plains Transportation Center (SPTC)," USDOT, \$7.7M
46. M. Zaman, "Matching Support for The Southern Plains Transportation Center," State of Oklahoma, Dept of Transportation, \$3M
47. K. De Beurs, "Storms, Forms, and Complexity of the Urban Canopy: How Land Use, Settlement Patterns, and the Shapes of Cities Influence Severe Weather," NASA, \$437K
48. E. Baron, "Models of Interacting Supernovae: Probing the Circumstellar Environment," NASA, \$381K
49. A. Fierro, K. Calhoun, E. Mansell, C. Ziegler, D. MacGorman, J. Gao, "Assimilation of GOES-R total lightning into GSI to improve short-term forecasts of high impact weather events at cloud resolving scales," NOAA, \$230K
50. M. Xue, K. Brewster, Y. Jung, , "Advanced Data Assimilation and Prediction Research for Convective-Scale 'Warn-on-Forecast'," NOAA, \$450K
51. M. Xue, F. Kong, Y. Jung, N. Snook, "mproving Initial Conditions and their Perturbations through Ensemble-Based Data Assimilation for Optimized Storm-Scale Ensemble Prediction in Support of HWT Severe Weather Forecasting," NOAA, \$249K

OSCER-FACILITATED FUNDING TO DATE:

\$447M total, \$205M to OU

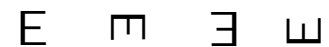

OSCER State of the Center Address

Wed Sep 21 2016



External Research Grants (cont'd)

52. M. Xue, K. Brewster, F. Kong, "Storm-Scale Ensemble Prediction Optimized for Heavy Precipitation Forecasting in Support of the Hydrometeorological Testbed (HMT)," NOAA, \$236K
53. J. Kelly, E. Bridge, P. Chilson, A. McGovern, K. deBeurs, J. Reedy, L. Jervis, "NRT: Aeroecology as a testbed of interdisciplinary STEM training," \$2.95M
54. F. Carr, J. Brotzge, "National Mesonet Program", GST and Earth Networks, \$50K
55. F. Carr, K. Brewster, "National Mesonet Program," \$100K
56. F. Carr, J. Brotzge, K. Brewster, "Network of Networks: Preliminary Study," NOAA/NWS Office of Science and Technology, \$210K

OSCER-FACILITATED FUNDING TO DATE:
\$447M total, \$205M to OU

OSCER State of the Center Address

Wed Sep 21 2016



External Research Grants (cont'd)

57. J. van de Lindt, B. Ellingwood, A. Cerato, N. Wang, C. Nicholson et al, "NIST Center for Risk-Based Community Resilience Planning," \$1.37M
58. J. van de Lindt, A. Cerato, N. Wang, "A Risk-Informed Decision Framework to Achieve Resilient and Sustainable Buildings that Meet Community Objectives," NSF, \$380K
59. J. Straka, K. Kanak, "Challenges in understanding tornadogenesis and associated phenomena," NSF, \$750K
60. J. Straka, "Challenges in understanding tornadogenesis and associated phenomena (supplement)," NSF, \$29K
61. P. Kirstetter, B. L. Cheong, T.-Y. Yu, "Deployment of a Novel Solid-state Polarimetric Weather Radar for Hydrology," NSF, \$87K
62. B. L. Cheong, R. D. Palmer, "Development of a Novel Solid-State Polarimetric Weather Radar PX-10,000," Nanowave Technologies, Inc., \$550,000,
63. K. Nicholas, "Catalytic Deoxydehydration," DOE, \$438K
64. M. Libault, "CAREER: Exploring the Transcriptional Regulatory Networks Controlling the Early Stages of Legume Nodulation," NSF, \$1.1M
65. B. Shiau, D. Papavassiliou, J. Harwell, "Interfacially active SWNT/silica nanohybrids," Advanced Energy Consortium, \$419K
66. S. Crowell, B. Moore, Y. Luo, "Improved Parameterization of Carbon Cycle Models Across Scales Using OCO-2 Measurements of XCO2 and SIF," NASA, \$477K
67. B. Wawrik, "MGMIC: Metagenome Analysis for Corrosion Tracking," OU Biocorrosion Center, \$131K
68. B. Wawrik, A. Callaghan, "Development of Techniques for the Quantification of Functional Gene Expression Associated with Biocorrosion," OU Biocorrosion Center, \$37K
69. B. Wawrik, D. Bronk, "Collaborative Research: Determining Rates of Group-specific Phytoplankton and Bacterial Uptake of Inorganic and Organic Nitrogen by means of Stable Isotope Techniques," NSF, \$770K
70. A. Callaghan, B. Wawrik, J. Suflita, "Biochemistry and Genetics of Anaerobic Alkane Metabolism: Interrogation of Sulfate-Reducing Isolates and Enrichments Using Genome-Enabled and Proteomic Approaches," NSF, \$725K
71. B. Wawrik, "Determining Rates of Group-specific Phytoplankton and Bacterial Uptake of Inorganic and Organic Nitrogen by Means of Stable Isotope Techniques," NSF, \$10K

OSCER-FACILITATED FUNDING TO DATE:

\$447M total, \$205M to OU



OSCER State of the Center Address

Wed Sep 21 2016



External Research Grants (cont'd)

72. B. Wawrik, G. Sinclair, "Transcriptomic Response to Nutrient Depletion of Marine Dinoflagellates," Gordon and Betty Moore Foundation, \$70K in-kind
73. Joseph M. Suflita. Co-PIs: A. Callaghan, L. Gieg, Z. He, B. Wawrik, J. Zhou, "Extending Knowledge of Anaerobic Hydrocarbon Metabolism: Linking Metabolism, Functional Gene Molecular Markers and the GeoChip," ConocoPhillips, \$999K
74. A. Striolo, "Anti-Agglomerants Performance in Hydrates Management: Fundamental Insights," EPSRC, £330K
75. A. Striolo et al, "ShaleXenvironment," European Commission, €3M
76. A. Striolo, "Flow Transport in Shale Rocks," Halliburton, £69K
77. A. Striolo, D. Cole, "Nanopore Confinement of C-H-(O) Mixed-Volatile Fluids Relevant to Subsurface Energy Systems," DOE, £60K
78. A. Striolo, "Hydrates Inhibitor Research," Halliburton, £69K
79. A. Striolo, "Fracking Fundamentals," Marie Curie Career Integration Grant, €100K
80. J. Li, "Targeting Mosquito FREP1 Protein for Malaria Control," NIH, \$424K
81. J. Li, "CAREER: Genetic and Molecular Mechanisms of Parasite Infection in Insects," NSF, \$783K
82. D. Atkins, J. Li, "Memory T cell-mediated protecting against malaria," NIH, \$76K
83. J. Li, "Genomics analysis of Anopheles gambiae mosquitoes to Plasmodium falciparum parasite Infection," OCAST, \$135K
84. P. Klein, P. B. Chilson, E. Fedorovich, A. Shapiro, D. Turner, "Low-level jets in the nocturnal stable boundary layer: structure, evolution, and interactions with mesoscale atmospheric disturbances," NSF, \$984K
85. E. Bridge, "The Electronic Transponder Analysis Gateway (ETAG): An Animal Behavior Observatory," NSF, \$315K
86. B. Capogrosso-Sansone, "Multi-Worm Algorithm for Path Integral Quantum Monte Carlo in Ultracold Dipolar Gases, NSF, \$293K
87. K. Dresback, R. Kolar, "Performance Optimization of the Advanced Circulation (ADCIRC) Model," Intel Parallel Computing Center, \$300K
88. U. Hansmann, "Modeling the molecular mechanism of amyloid oligomer and fibril self assembly," OCAST, \$90K

OSCER-FACILITATED FUNDING TO DATE:

\$447M total, \$205M to OU

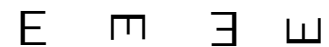

OSCER State of the Center Address

Wed Sep 21 2016

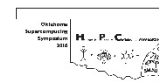

External Research Grants (cont'd)

89. J. Wicksted, A. Knoedler et al, "Adapting Socio-ecological Systems to Increased Climate Variability," NSF, \$20M + \$4M Regents (total), \$7.0M + \$1.9M Regents (OU)
90. M. Engle et al, "Resilience and vulnerability of beef cattle production in the Southern Great Plains under changing climate, land use and markets," \$9.5M (total), \$1.9M (OU)
91. R. Palmer, G. Zhang, Y. Zhang, T. Yu, M. Yeary, S. Karimkashi, C. Fulton, B. Cheong, "Multi-Mission Phased Array Radar Risk Reduction: A Collaborative Effort with the ARRC at the University of Oklahoma," NOAA, \$1.5M
92. R. Palmer, G. Zhang, Y. Zhang, T. Yu, M. Yeary, Y. Hong, J. Crain, P. Chilson, "Next Generation Weather Radar Technology," NOAA, \$900K
93. R. Palmer, D. Bodine, S. Torres, B. Cheong, C. Fulton, "Understanding Polarimetric Radar Tornadic Debris Signatures Using Modeling, Simulations, and Field Measurements,," NSF, \$860K
94. A. Callaghan, "Elucidation of Alkene Metabolism in Two Sulfate-reducing Isolates via Metabolite Profiling and Transcriptomics," NSF, \$848K
95. D. LaDue, K. Kloesel, "REU Site: Research Experiences for Undergraduates at the National Weather Center," NSF, \$822K
96. J. Brotzge, M. Xue, N. Snook, Y. Jung, A. McGovern, "The Severe Hail Analysis, Representation, and Prediction (SHARP) Project," NSF, \$819K
97. L. Krumholz, J. Zhou, M. McInerney, J. Wall, "Characteristics of H2 Producing Biological Systems Operating at 1 nM H2 Concentration," DOE, \$819K (total), \$693K (OU)
98. P. Chilson, E. Fedorovich, R. Palmer, "Studies of the Atmospheric Boundary Layer Using Numerical Simulations Coupled With Radar/Sodar-Based Field Experiments," NSF, \$757K
99. M. Xue, K. Brewster, F. Kong, "Establishment of Precision Weather Analysis and Forecasting Systems (PWAFS) for the Jiangsu Province Meteorological Bureau (JSMB)," NRIET, \$505K
100. H. Neeman, D. Brunson, J. Deaton, S. Radhakrishnan et al, "CC-NIE: OneOklahoma Friction Free Network," NSF, \$500K
101. F. Kong, M. Xue, "Further Development of the Storm-Scale Numerical Weather Prediction Capability for Shenzhen Meteorological Bureau," Shenzhen, \$479K
102. E. Bridge, J. Kelly, "Optimizing Grassland Bird Conservation in an Era of Biofuel Production," USDA, \$466K

OSCER-FACILITATED FUNDING TO DATE:

\$447M total, \$205M to OU

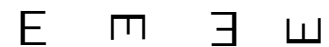

OSCER State of the Center Address

Wed Sep 21 2016



External Research Grants (cont'd)

- 103. R. Kolar, "Dynamic Integration of Natural, Human, and Instructure Systems for Hurricane Evacuation and Sheltering," NSF, \$456K
- 104. L. Ding, "Neuroimaging Study of Mental Fatigue," FAA, \$430K
- 105. U. Hansmann, "Development of Generalized-Ensemble Algorithms and their Application in Protein Studies," NSF, \$410K
- 106. L. Ding, "Large-Scale Computational Neuroimaging of Brain Electrical Activity," NSF CAREER, \$400K
- 107. P. Attar, "Optimal Spatiotemporal Reduced Order Modeling for Nonlinear Structural Dynamics," NSF, \$360K
- 108. B. L. Cheong, Y. Jung, G. Zhang,, "Support for X-band Solid-state Weather Radar Development," WeatherLink, \$334K
- 109. P. Vedula, P. J. Attar, "Fast simulations of turbulent flows based on spatiotemporal statistical information," NSF, \$330K
- 110. M. Xue, K. Brewster, F. Kong, "Development of a Short-Range Realtime Analysis and Forecasting System based on the ARPS for Taiwan Region Year 3 (IA#24) and Year 4 (IA #25)," NOAA, \$310K
- 111. E. Bridge, J. Kelly, X. Xiao, "Enhancing and disseminating miniaturized tracking technology for widespread use on small migratory songbirds," NSF, \$302K
- 112. J. Kelly, L. Gruenwald, P. Chilson, V. Lakshmanan, E. Bridge, "Advancing Biological Interpretations of Radar Data," NSF EAGER, \$299K
- 113. L. Ding, "High-Resolution Noninvasive Computational Neuroimaging," OCAST, \$283K
- 114. F. Kong, "Further Development to the Storm-Scale Numerical Weather Prediction Capability for Shenzhen Meteorological Bureau," SIATCAS, \$251K
- 115. R. Slatt, Consortium from 14 oil and gas company, \$245K
- 116. J. Brotzge, F. Carr, "Prototyping and Evaluating Key Network-of-Networks Technologies: Project Extension," NOAA, \$210K
- 117. Y. Jung, M. Xue, G. Zhang, "Development of a Polarimetric Radar Data Simulator for KLAPS," KMA, \$176K
- 118. J. Ruyle, "BRIGE: Investigation of Slot Antenna Recon figuration Mechanisms," NSF, \$175K
- 119. J. Brotzge, F. Carr, "CASA Warning System Innovation Institute," U Mass, \$160K

OSCER-FACILITATED FUNDING TO DATE:

\$447M total, \$205M to OU

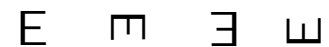

OSCER State of the Center Address

Wed Sep 21 2016

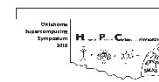

External Research Grants (cont'd)

120. J. Kelly, "Developing Innovative Tools to Use Weather Radar Data to Assess and Monitor Impacts of Existing and Future Energy Facilities on Aerial Faunas in California," CIEE, \$150K (total), \$49K (OU)
121. J. Brotzge, F. Carr, "Prototyping and Evaluating Key Network-of-Networks Technologies," NOAA, \$145K
122. T. Yu, Y. Wang, R. Palmer, B. Cheong, "Algorithm development for solid-state polarimetric weather radars," Toshiba, \$130K
123. M. Xue, K. Brewster, F. Kong, "Establishment of an Urban-Scale Weather Forecasting System (USWFS) for the Su Zhou Meteorological Bureau (SZMB)," \$127K
124. L. Ding, "Neurophysiological Assessment of Mental Fatigue and Cognitive Performance," FAA, \$115K
125. K. Dresback, R. Kolar, "Next Generation ADCIRC Tidal Database: Phase 2 - West Coast," DOD, \$75K
126. K. Dresback, R. Kolar, "Next Generation ADCIRC Tidal Database," NOAA, \$75K
127. P. Risser, J. Duckles, J. Bratton, NSF I-Corps, \$50K
128. R. Palmer, M. Yeary, "System and Software Engineering Support Services for CGI," CGI, \$46K
129. M. Yeary, M. Xue, "GRDS: Request to support a Native American Indian graduate student beginning his PhD within the CASA Engineering Research Center," NSF, \$32K

OSCER-FACILITATED FUNDING TO DATE:

\$447M total, \$205M to OU

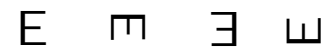

OSCER State of the Center Address

Wed Sep 21 2016



External Research Grants (cont'd)

121. I.Y. Akkutlu, J. Callard, C. Rai, C. Sondergeld, "OU Shale Gas and Unconventional Reservoir Research Cooperative," \$2.8M per year
122. J. P. Shaffer, T. Pfau, "A Rydberg Atom Electric Field Sensor," DARPA-ARO, \$1.18M (total), \$1.06M (OU)
123. Y. Luo, "Data Synthesis and Data Assimilation at Global Change Experiments and Fluxnet toward Improving Land Process Models," DOE, \$1.05M
124. F. Kong, M. Xue, K. Brewster, "Establishment of an Improved Numerical Weather Forecasting System for Chongqing Meteorological Service," Chongqing Institute of Green and Intelligent Technology, China, \$852K
125. G. Zhang, M. Xue, B. L. Cheong, T. J. Schurr, "Advanced Study of Precipitation Microphysics with Multi-Frequency Polarimetric Radar Observations and Data Assimilation," NSF, \$637K
126. J. P. Shaffer, "A Quantum Hybrid System for Linking Rydberg Atom Quantum Gates. NSF, \$465K
127. J. P. Shaffer, "Rydberg Atom Interactions and Collective Behavior," NSF, \$436K
128. J. P. Shaffer, "Interactions in Cold Rydberg Gases," NSF, \$422K
129. J. Cruz, "CIF: Small: Two-Dimensional Channel Modeling, Detection and Coding for Shingled Magnetic Recording," NSF, \$418K
130. M. Yuan, "Supplement to Developing and Evaluating the Effectiveness of the Location-based Offender Monitoring System for Offender Supervision," National Institute of Justice, \$396K
131. X. Wang, M. Xue, F. Kong, "Optimal Design of Multi-scale Ensemble Systems for Convective-Scale Probabilistic Forecasting," NSF, \$359K
132. F. Kong, M. Xue, "Further Development of the Storm-Scale Numerical Weather Prediction Capability for Shenzhen Meteorological Bureau," Shenzhen Institute of Advanced Technology, China, \$251K
133. J. Snow & F. Fondjo Fotou (Langston U), "MRI: Acquisition of a High Performance Computing Cluster for Research and Education," NSF, \$250K
134. M. Xue, K. Brewster, Y. Jung, "Advanced Data Assimilation and Prediction Research for Convective-Scale Warn-on-Forecast," NOAA, \$243K
135. I.Y. Akkutlu, "Multi-scale Characterization of Transport Phenomena in Shales for Improved Gas Recovery," Devon Energy, \$200K
136. M. Xue, R. McPherson, J. Brotzge, B. Moore, "Very High-Resolution Dynamic Downscaling of Regional Climate and Hydrology," USG, \$24K
137. J. Brotzge, F. Carr, "CASA DFW Testbed Enhancement: Task B of National Mesonet Program (NWP)," Earth Networks Inc., \$25K

OSCER-FACILITATED FUNDING TO DATE:

\$447M total, \$205M to OU



OSCER State of the Center Address

Wed Sep 21 2016

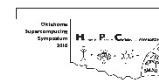

External Research Grants (cont'd)

138. R. Voronov, "Intra-Thrombus Chemo-Transport and Local Stress Mechanics under Flow," American Heart Association Postdoctoral Fellowship, \$150K
139. X. Wang, M. Xue, "Improving High Resolution Tropical Cyclone Prediction using GSI-based Hybrid Ensemble-Variational Data Assimilation System for HWRF," NOAA, \$150K
140. I. Y. Akkutlu, "Molecular Theory of Capillarity in Kerogen - A Multi-component Approach to Predict Shale Gas/Liquid In-place and Transport in Nanopores," Devon Energy, \$150K
141. S. Dhall, L. Gruenwald, "Autonomous Database Partitioning using Data Mining for High End Computing," NSF, \$150K
142. M. Xue, K. Brewster, F. Kong, "Ensemble Simulation of GOES-R Proxy Radiance Data from CONUS Storm-Scale Ensemble Forecasts, Product Demonstration and Assessment at the Hazardous Weather Testbed GOES-R Proving Ground," NOAA, \$126K
143. M. Xue, K. Brewster, F. Kong, "Ensemble Simulation of GOES-R Proxy Radiance Data from CONUS Storm-Scale Ensemble Forecasts, Product Demonstration and Assessment at the Hazardous Weather Testbed GOES-R Proving Ground," NOAA, \$94K
144. K. Brewster, M. Xue, "High Resolution Data Assimilation for Trajectory Improvement," DOD-Air Force, \$79K
145. F. Kong, "CAPS support to the WRF Lightning Forecast Algorithm for the NOAA R3 effort," NOAA GOES-R/Universities Space Research Assn, \$48K
146. R. McPherson, M. Shafer, Y. Hong, "Utilization of Regional Climate Science Programs in Reservoir and Watershed Impact Assessments," OSU Water Resources Responses to Climate Change: Pilot Study, \$43K
147. P. Attar, "Numerical Simulation of a Membrane Micro Air Vehicle in a Gust Field, Ohio Aerospace Institute, \$35K
148. J.R. Cruz, "Signal Processing for Magnetic Recording Channels," Hitachi Global Storage Technologies, Inc., Director, \$30K
149. J.R. Cruz, "Equalization, Detection, and Coding Algorithms for Bit Patterned Media Recording," Advanced Storage Technology Consortium, \$17K
150. L. Sells, J. Goulden, H. Aboudja, "LittleFe grant," LittleFe project, \$2.5K
151. L. Sells, J. Goulden, "Early Adopter Grant," NSF/TCPP, \$2.5K

OSCER-FACILITATED FUNDING TO DATE:

\$447M total, \$205M to OU



OSCER State of the Center Address

Wed Sep 21 2016

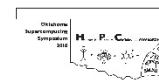

External Research Grants (cont'd)

- 152. B. Moore III et al, "Department of the Interior South-Central Regional Climate Science Center," US Dept of the Interior, \$3.5M (total), \$1.4M (OU)
- 153. A. Striolo, D. Resasco et al, "Center for Application of Single-Walled Carbon Nanotubes," DOE, \$1M
- 154. J. K. Shen, "CAREER: Electrostatic Mechanisms in Protein Stability and Folding, NSF, \$773K
- 155. Y. Kogan, "Parameterization of cumulus convective cloud systems in mesoscale forecast models," ONR, \$594K
- 156. X. Wang, M. Xue, F. Kong, "Optimal Design of Multi-scale Ensemble Systems for Convective-Scale Probabilistic Forecasting," NSF, \$395K
- 157. R. D. Palmer, T.-Y. Yu, "NMQ and WDSS-II for the KMA radar network: Real-time, effective, and integrated weather products," Space Environment Laboratory, Inc., \$361K
- 158. B. Grady, A. Striolo, "Novel Supramolecular Structures of Laterally Confined Amphiphilic Molecules," NSF, \$335K
- 159. D. Resasco, D. Papavassiliou et al, "Interfacially active SWNT/silica nanohybrids," Advanced Energy Consortium, \$331K
- 160. C. Y. Tang , R. Ramakumar, N. Jiang , "Control and Operation of Large-Scale Wind Farms in the Power System", NSF, \$231K
- 161. J. Shen, "Electrostatic Modulation of Protein Stability and Folding," NIH, \$1.4M
- 162. Y. Wang, "Theoretical Tools for Measuring Dark Energy from Galaxy Clustering," DOE, \$230K
- 163. F. Kong, M. Xue, "Further Enhancement to the Hourly Assimilation and Prediction System (HAPS) for Shenzhen Meteorological Bureau." Shenzhen Institute of Advanced Technology, Chinese Academy of Science, \$228K
- 164. P. Attar, P. Vedula, "Multi-fidelity Modeling and Simulation (M&S) Tool for Nonlinear Aeroelasticity," Advanced Dynamics, \$160K
- 165. B. Eskridge, "CDI-TYPE I: RUI: Emergent Hierarchies of Leaders in Multi-Robot Systems," NSF, \$159K
- 166. A. Striolo, "Mixed-Volatile Fluids Relevant to Subsurface Energy Systems," DOE, \$120K
- 167. P. Skubic, M. Strauss, "OU Contribution to the ATLAS Southwest Tier 2 Computing Center (Supplement)," NSF, \$110K
- 168. P. Attar, "High-Fidelity Computational Aeroelastic Solver Research," Ohio Aerospace Institute, \$53K
- 169. P. Skubic, M. Strauss, "OU Contribution to the ATLAS Southwest Tier 2 Computing Center (Supplement)," NSF, \$50K

OSCER-FACILITATED FUNDING TO DATE:
\$447M total, \$205M to OU



OSCER State of the Center Address

Wed Sep 21 2016

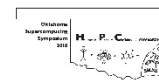

External Research Grants (cont'd)

170. P. Skubic, M. Strauss, "University of Oklahoma Contribution to OSG Software Development," Brookhaven National Laboratory, \$50K.
171. P. Attar, "Computational Model Development and Experimental Validation Measurements for Membrane-Batten Wing," Ohio Aerospace Institute, \$43K
172. A. Striolo, "Reduced Carbon in Earth's Crust and Mantle I," Alfred P. Sloan Foundation, \$39K.
173. J. Gao, "Advancing Research on Realtime Weather-Adaptive 3DVAR Analyses with Automatic Storm Positioning and On-demand Capability," NOAA, \$36K
174. M. Xue, "Probabilistic Forecasting for Aviation Decision Aid Applications," Impact Technologies, \$20K
175. P. Attar, P. Vedula, "Towards Better Modeling and Simulation of Nonlinear Aeroelasticity On and Beyond Transonic Regimes," Advanced Dynamics, \$20K
176. P. Attar, P. Vedula, "High-Fidelity Computational Aeroelastic Models in Support of Certification Airworthiness of Control Surfaces with Freeplay and Other Nonlinear Features," Advanced Dynamics, \$9K

**OSCER-FACILITATED FUNDING TO DATE:
\$447M total, \$205M to OU**

OSCER State of the Center Address

Wed Sep 21 2016

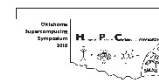

External Research Grants (cont'd)

- 177. H. Neeman, D. Brunson (OSU), J. Deaton (OneNet), J. He (Noble Foundation), D. Schoenefeld (TU), J. Snow (Langston U), M. Strauss (OU), X. Xiao (OU), M. Xue (OU), "Oklahoma Optical Initiative," NSF, \$1.17M
- 178. H. Neeman, M. Jensen, M. Strauss, X. Xiao, M. Xue, E. Baron, K. Dresback, R. Kolar, A. McGovern, R. Palmer, D. Papavassiliou, H. Severini, P. Skubic, T. Trafalis, M. Wenger, R. Wheeler (Duquesne U), "MRI: Acquisition of Extensible Petascale Storage for Data Intensive Research," NSF, \$793K
- 179. D. Resasco, J. Harwell, F. Jentoft, K. Gasem, S. Wang, "Center for Interfacial Reaction Engineering (CIRE)," DOE EPSCoR, \$2.4M (\$1.97M OU)
- 180. P. Skubic, M. Strauss, B. Abbott, P. Gutierrez, "Experimental Physics Investigations Using Colliding Beam Detectors at Fermilab and the Large Hadron Collider (LHC) (TASK A) 2010-2013 Renewal," DOE, \$2.8M
- 181. R. Palmer, Y. Zhang, G. Zhang, T. Yu, M. Yeary, Y. Hong, J. Crain, P. Chilson, "Next Generation Phased Array," NSSL, \$2M
- 182. P. Skubic, M. Strauss, B. Abbott, P. Gutierrez, "Experimental Physics Investigations Using Colliding Beam Detectors at Fermilab and the Large Hadron Collider (LHC) (TASK A) 2010-2013 Renewal-Revision," DOE, \$1.52M
- 183. D. Cole, Alberto Striolo, "Structure and Dynamics of Earth Materials, Interfaces and Reactions," DOE, \$1.5M (\$90K OU)
- 184. R. Sigal, F. Civan, D. Devegowda, "Simulation of Shale Gas Reservoirs Incorporating the Correct Physics of Capillarity and Fluid Transport," Research Partnership to Secure Energy for America (RPSEA), \$1.05M
- 185. M. Biggerstaff, J. Straka, L. Wicker, Zrnica, Zahari, "MRI Development of C-Band Mobile Polarimetric Weather Radars," NSF, \$989K (\$439K OU)
- 186. D. Resasco, D. Papavassiliou et al, "Carbon Nanotube Technology Center," DOE, \$925K
- 187. M. Saha, D. Papavassiliou, A. Striolo, K. Mullen, B. Grady, C. Altan, D. Resasco, "Experimental and theoretical studies of carbon nanotube hierarchical structures in multifunctional polymer composites," DoD-EPSCoR, \$897K
- 188. E. Mansell, J. Straka, C. Ziegler, D. MacGorman, "Numerical modeling studies of storm electrification and lightning," NSF, \$817K
- 189. E. Rasmussen, J. Straka, K. Kanak, "Collaborative Research: Challenges in understanding tornadogenesis and associated phenomena, \$755K (\$489K OU)
- 190. J. Straka, K. Kanak, "Challenges in tornadogenesis and associated phenomena," NSF, \$584K

OSCER-FACILITATED FUNDING TO DATE:

\$447M total, \$205M to OU



OSCER State of the Center Address

Wed Sep 21 2016

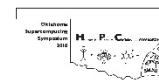

External Research Grants (cont'd)

191. M. Xue, F. Kong, "Advanced Multi-Moment Microphysics for Precipitation and Tropical Cyclone Forecast Improvement with COAMPS," ONR, \$592K
192. J. Straka, K. Kanak, "Collaborative Research: Challenges in Understanding Tornadoogenesis and Associated Phenomena," NSF, \$515K
193. D. MacGorman, E. Mansell, C. Ziegler, A. Fierro, M. Xue, "Techniques for Assimilating Geostationary Lightning Mapper Data and Assessment of the Resulting Impact on Forecasts," NOAA, \$415K
194. M. Xue, F. Kong, K. Brewster, X. Wang, "A Partnership to Develop, Conduct, and Evaluate Realtime High-Resolution Ensemble and Deterministic Forecasts for Convective-scale Hazardous Weather: Moving to the Next Level," NOAA CSTAR, \$375K
195. M. Xue, K. Brewster, J. Gao, X. Wang, "Advanced Data Assimilation and Prediction Research for Convective-Scale 'Warn-on-Forecast,'" \$500K, NOAA
196. X. Wang, "Improving satellite radiance data assimilation using a hybrid ensemble-Gridpoint Statistical Interpolation (GSI) method for global numerical weather prediction," NASA, \$276K
197. X. Wang, M. Xue, "Improving NOAA operational global numerical weather prediction using a hybrid-ensemble Kalman filter data assimilation and ensemble forecast system," NOAA, \$207K
198. D. Resasco, D. Papavassiliou et al, "Interfacially active SWNT/silica nanohybrids," Advanced Energy Consortium (AEC), \$333K
199. D. Oliver, "Data analysis and inversion for mobile nanosensors," AEC, \$320K
200. R. Palmer, T. Yu, G. Zhang, M. Yearly, P. Chilson, Y. Zhang, J. Crain, "Advancements in Phased Array Weather Radar Research at OU," NOAA National Severe Storms Laboratory (NSSL), \$270K
201. A. Striolo, "The Emergent Behavior of Solid Nanoparticles at Oil-Water Interfaces: A Multi-Scale Thermodynamic Approach to Enable Bio-Oil Upgrade," NSF, \$238K
202. M. Xue, K. Brewster, F. Kong, "Development of a Short-Range Realtime Analysis and Forecasting System based on the ARPS for Taiwan Region," NOAA, \$200K
203. J. Straka, K. Kanak, "Formative dynamics of the mammatus clouds in thunderstorm cirrus," NSF, \$318K
204. M. Yearly, C. Tang, "Computationally Efficient Linear Transforms for Remote Sensing Systems," NSF, \$299K
205. A. Striolo, "Probing regular solution theory for mixed amphoteric/ionic surfactant systems by molecular dynamics simulations," ACS, \$100K

OSCER-FACILITATED FUNDING TO DATE:

\$447M total, \$205M to OU



OSCER State of the Center Address

Wed Sep 21 2016



External Research Grants (cont'd)

- 206. K. Brewster, M. Xue, F. Kong, meteorology project, \$211K
- 207. M. Xue, meteorology project, \$120K
- 208. A. McGovern, "Learning to guide search in large state spaces," IBM DARPA, \$95K
- 209. J. Straka, K. Kanak, "Supplement: Challenges in tornadogenesis and associated phenomena (VORTEX2)," NSF, \$87K
- 210. F. Kong, M. Xue, "Establishment of an Experimental Real-Time Short-Term Storm Prediction System for Shenzhen Meteorological Bureau," \$58K
- 211. J. Straka, "Improved Understanding/Prediction of Severe Convective Storms and Attendant Phenomena through Advanced Numerical Simulation," NSF, \$58K
- 212. M. Xue, "Assimilation of NEXRAD Radial Winds in a Regional Mesoscale Model," Miss State U, \$79K
- 213. J. Cruz, R. Todd, "Medium-Density Parity-Check Codes for Tape Systems," INSIC, \$36K
- 214. M. Xue, D. Stensrud, J. Gao, "Advancing Warn on Forecast – Storm-scale Analysis of Vortex 2 Thunderstorms," NSSL, \$70K
- 215. P. Attar, "High-Fidelity Computational Aeroelastic Solver Research," Ohio Aerospace Institute, \$60K
- 216. J. Straka, K. Kanak, "Development of Unmanned Aircraft System for Research in a Severe Storm Environment and Deployment within the VORTEX 2," NSF, \$44K
- 217. J. Cruz, "Equalization, Detection, and Coding Algorithms for Bit Patterned Media Recording Channels," International Storage Industry Consortium (INSIC), \$35K
- 218. J. Cruz, R. Todd, "Signal Processing for Magnetic Recording Channels," private company, \$30K
- 219. P. Attar, P. Vedula, "Deterministic and Statistical Characterization of the Impact of Control Surface Freeplay on Flutter and Limit-Cycle Oscillation (LCO) using Efficient Computational Modeling," Advanced Dynamics, \$30K
- 220. P. Attar, P. Vedula, "Novel Reduced Order in time Models for Problems in Nonlinear Aeroelasticity," Advanced Dynamics, \$29K
- 221. F. Carr, J. Straka, "Severe storm research," Jonathon Merage Foundation, \$21K
- 222. F. Carr, J. Straka, "Severe storm research," Jonathon Merage Foundation, \$20K

OSCER-FACILITATED FUNDING TO DATE:

\$447M total, \$205M to OU E M E W

OSCER State of the Center Address

Wed Sep 21 2016



External Research Grants (cont'd)

- 223. A. Striolo, "Electrolytes at Solid-Water Interfaces: Theoretical Studies for Practical Applications," DOE EPSCoR, \$450K
- 224. A. Striolo, Saha, "Experimental and Theoretical Studies of Carbon Nanotube Hierarchical Structures in Multifunctional Polymer Composites," DOD EPSCoR, \$450K
- 225. D. Cole (ORNL), A. Striolo, "Structure and Dynamics of Earth Materials, Interfaces and Reactions," DOE, \$1.5M (\$75K OU)
- 226. D. Papavassiliou, A. Striolo, "Effects of Hydrophobicity-Induced Wall Slip on Turbulence Drag and Turbulence Structure," NSF, \$230K
- 227. A. Striolo, D. Resasco, U. Nollert, "Understanding the Interactions between Carbon Nanotubes and Cellular Membranes," NSF, \$380K
- 228. M. Xue, Y. Hong, X. Hu (GSU), "Integrated Weather and Wildfire Simulation and Optimization for Wildfire Management," NSF, \$997K (\$483K OU)
- 229. Y. Hong, "Next Generation QPE: Toward a Multi-Sensor Approach for Integration of Radar, Satellite, and Surface Observations to Produce Very High-resolution Precipitation Data," NOAA/OAR/NSSL via CIMMS, \$83K
- 230. R. Palmer, Y. Hong, "Phased Array Technology for Weather Radar Applications," NOAA/OAR/NSSL via CIMMS, \$426K
- 231. Y. Hong, Baski (OSU), "Proactive approach to transportation resource allocation under severe winter weather emergencies," OK-DOT/OTC, \$261K (\$101K OU)
- 232. R. Palmer, Y. Hong, "Atmospheric Observations using PhasedArray Technology," \$340K
- 233. Y. Hong, "Toward Improved Flood Prediction and Risk Mitigation: Capacity Building for Africa," NASA, \$87K
- 234. Y. Hong, "Improving NASA Global Hazard System and Implementing SERVIR-Africa," NASA, \$272K
- 235. Y. Hong, "Link SERVIR-Africa Work to NASA Land Information System: Workshop Training and Data Assimilation of GRACE to NASA-OU Hydrologic Model," NASA, \$10K
- 236. R. Adler (NASA), Y. Hong, "Global Hazard (Flood-Landslide) Decision-Support System," NASA, \$900K
- 237. S. Schroeder, "CAREER: Advancing Viral RNA Structure Prediction," NSF, \$750K

OSCER-FACILITATED FUNDING TO DATE:

\$447M total, \$205M to OU E M E W

OSCER State of the Center Address

Wed Sep 21 2016



External Research Grants (cont'd)

- 238. P. Attar, "High Fidelity Computational Aeroelastic Analysis of a Flexible Membrane Airfoil Undergoing Dynamic Motion," Ohio Aerospace Institute, \$35K
- 239. P. Attar, "Computational Model Development and Experimental Validation Measurements for Membrane-Batten Wing" Flexible Membrane Airfoil Undergoing Dynamic Motion," Ohio Aerospace Institute, \$43K
- 240. K. Droegemeier, F. Kong, P. Attar, "A Partnership to Develop, Conduct, and Evaluate Realtime High-Resolution Ensemble and Deterministic Forecasts for Convective-scale Hazardous Weather," NOAA, \$375K
- 241. M. Xue, G. Zhang, K. Brewster, F. Kong, "Prediction and Predictability of Tropical Cyclones over Oceanic and Coastal Regions and Advanced Assimilation of Radar and Satellite Data for the Navy Coupled Ocean-Atmosphere Mesoscale Prediction System," ONR/DOD EPSCoR, \$476K; OK Board of Regents \$100K
- 242. S. Ahalt, A. Apon, D. Lifka, H. Neeman, "NSF Workshop High Performance Computing Center Sustainability," NSF, \$49K (\$0 OU)
- 243. Y. Luo, S. Lakshmivarahan, "Development of a Data Assimilation Capability towards Ecological Forecasting in a Data-Rich Era," NSF, \$1.08M
- 244. Y. Luo, D. Schimmel (NEON), J. Clark (Duke U.), Kiona Ogle (U. Wyoming), S. LaDeau (Cary Institute of Ecosystem Study), "RCN: Forecasts Of Resource and Environmental Changes: Data Assimilation Science and Technology (FORECAST)," NSF, \$500K
- 245. J. Straka, K. Kanak, Davies-Jones, H. Neeman, "Challenges in understanding tornadogenesis and associated phenomena," NSF, \$854K
- 246. P. Risser et al, "A cyberCommons for Ecological Forecasting," NSF, \$6M (\$2.78M OU)
- 247. M. Xue, X. Wang, X. Li (OSU), R. Barnes, S. Sanielevici (PSC), H. Neeman, "Enabling Petascale Ensemble-Based Data Assimilation for the Numerical Analysis and Prediction of High-Impact Weather," NSF, \$1.2M (\$902K OU)
- 248. P. Skubic, B. Abbott, P. Gutierrez, M. Strauss, "ATLAS Southwest Tier 2 Computing Center," NSF, \$600K/year (\$60K/year OU)
- 249. Y. Hong, "Evaluation of NASA Global Hazard System," NASA, \$45K

OSCER-FACILITATED FUNDING TO DATE:
\$447M total, \$205M to OU

OSCER State of the Center Address

Wed Sep 21 2016

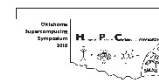

External Research Grants (cont'd)

- 250. J Wicksted, F. Waxman et al, "Building Oklahoma's Leadership Role in Cellulosic Bioenergy," NSF EPSCoR, \$15M (\$5.7M OU)
- 251. D.S. Oliver, software, \$16.7M
- 252. K.K. Muraleetharan, G. Miller, and A. Cerato, "Understanding and Improving the Seismic Behavior of Pile Foundations in Soft Clays," NSF, \$1.15M (\$500K OU)
- 253. K. Droegemeier, F. Kong, "Multisensor Studies of Precipitation for Model Verification and Data Assimilation," U Minn, (\$7K OU)
- 254. K. Droegemeier, M. Xue, F. Kong, "Observing System Simulation Experiments for Airborne Weather Sensors," HRL, (\$33K OU)
- 255. M. Nollert, Scholarship, FD-OMRF, \$12K
- 256. R. Sigal, R. Philp, C. Rai., S. Shah, R. Slatt, C. Sondergeld, D. Zhang, energy company, \$1.9M
- 257. B. Grady, D. Schmidtke, A. Striolo, A. Cheville, D. Teeters, "Polymer Nanostructures on Solid Surfaces," \$208K (\$125K OU)
- 258. T. Conway, "E. coli Model Organism Resource," UN-Purdue, (\$685K OU)
- 259. R. Kolar, "Storm Surge Modeling in SE Louisiana - 2006," ARCADIS, (\$37K OU)
- 260. D. Cole (ORNL), A. Striolo, "Rates and Mechanisms of Mineral-Fluid Interactions at the Nanoscale," DOE, \$1.65M (total), (\$55K OU)
- 261. R. Kolar, "A Prototype Operational Modeling System for Waves, Coastal Currents, Inundation and Hydrologic Flooding for Eastern North Carolina," UN-UNC-CH, (\$209K OU)
- 262. R. Kolar, "A Coupled Regional-Coastal Ocean Model: HYCOM/CG-ADCIRC," DOD-NRL, (\$333K OU)
- 263. M. Xue, "Contribution to WRF Model Development by the Center for Analysis and Prediction of Storms," DOC-NOAA, \$821K
- 264. K. Marfurt, "Improving Geologic and Engineering Models of Midcontinent Fracture and Karst Modified Reservoirs Using 3-D Seismic Attributes," UKCRINC, (\$61K OU)
- 265. P. Attar, P. Vedula, "Novel, Optimal, Physics-based Reduced Order Models for Nonlinear Aeroelasticity," Advanced Dynamics, \$49K
- 266. S. Dhall, "Autonomous Data Partitioning using Data Mining for High Performance Computing," NSF, (\$125K OU)

OSCER-FACILITATED FUNDING TO DATE:

\$447M total, \$205M to OU

OSCER State of the Center Address

Wed Sep 21 2016



External Research Grants (cont'd)

267. M. Xue, K. Brewster, J. Gao, "Ensemble-based Data Assimilation for Tropical Storms, and Realtime 3DVAR Analysis for Initial Proof of 'Warn-on-Forecast' Concept: Collaborative Research between CAPS and NSSL," DOC-NOAA, \$100,000
268. M. Xue, "Contribution to Model Development and Enhancement Research Team by the Center for Analysis and Prediction of Storms," DOC-NOAA, \$620K
269. M. Xue, K. Brewster, "Ensemble-based Data Assimilation for Convective Storms and Hurricanes," DOC-NOAA, \$100,000
270. S. Schroeder, "Discovering Satellite Tobacco Mosaic Virus Structure," OCAST, \$85K
271. S. Schroeder, "Computational Advances Toward Predicting Encapsidated Viral RNA Structure," Pharmaceutical Research and Manufacturer's Association of America, \$60K
272. R. Kolar, "Outer Boundary Forcing for Texas Coastal Models," Texas Water Development Board, \$20K
273. K. Milton, "Collaborative Research: Quantum Vacuum Energy", NSF, \$250K
274. A. McGovern, "Developing Spatiotemporal Relational Models to Anticipate Tornado Formation," NSF, \$500K
275. Y. Kogan, "Midlatitude Aerosol-Cloud-Radiation Feedbacks in Marine Boundary Layer Clouds", ONR, \$638K
276. J. Straka, K. Kanak, Davies-Jones, "Challenges in understanding tornadogenesis and associated phenomena," NSF, \$854K (total), \$584K (OU)
277. Y. Hong, "Improvement of the NASA Global Hazard System and Implement Server-Africa," NASA, \$272K
278. J. Antonio, S. Lakshmivarahan, H. Neeman, "Predictions of Atmospheric Dispersion of Chemical and Biological Contaminants in the Urban Canopy." Subcontract No. 1334/0974-01, Prime Agency DOD-ARO, Subcontract through Texas Tech University, Lubbock, TX, Sep. 29, 2000 to Nov. 3, 2001, \$75K
279. A. Striolo, "Electrolytes at Solid-Water Interfaces: Theoretical Studies for Practical Applications," OSRHE Nanotechnology, \$15K
280. D. Papavassiliou, "Turbulent transport in non-homogeneous turbulence," NSF, \$320K

OSCER-FACILITATED FUNDING TO DATE:
\$447M total, \$205M to OU

OSCER State of the Center Address

Wed Sep 21 2016

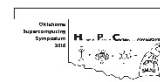

External Research Grants (cont'd)

- 281. K. Droegemeier et al., "Engineering Research Center for Collaborative Adaptive Sensing of the Atmosphere," NSF, \$17M (total), \$5.6M (OU)
- 282. K. Droegemeier et al., "Linked Environments for Atmospheric Discovery (LEAD)," NSF, \$11.25M (total), \$2.5M (OU)
- 283. M. Strauss, P. Skubic et al., "Oklahoma Center for High Energy Physics", DOE EPSCoR, \$3.4M (total), \$1.6M (OU)
- 284. M. Richman, A. White, V. Lakshmanan, V. DeBrunner, P. Skubic, "Real Time Mining of Integrated Weather Data," NSF, \$950K
- 285. D. Weber, K. Droegemeier, H. Neeman, "Modeling Environment for Atmospheric Discovery," NCSA, \$435K
- 286. H. Neeman, K. Droegemeier, K. Mish, D. Papavassiliou, P. Skubic, "Acquisition of an Itanium Cluster for Grid Computing," NSF, \$340K
- 287. J. Levit, D. Ebert (Purdue), C. Hansen (U Utah), "Advanced Weather Data Visualization," NSF, \$300K
- 288. D. Papavassiliou, "Turbulent Transport in Wall Turbulence," NSF, \$165K
- 289. L. Lee, J. Mullen (Worcester Polytechnic), H. Neeman, G.K. Newman, "Integration of High Performance Computing in Nanotechnology," NSF, \$400K
- 290. R. Wheeler, "Principal mode analysis and its application to polypeptide vibrations," NSF, \$385K
- 291. R. Kolar, J. Antonio, S. Dhall, S. Lakshmiarahan, "A Parallel, Baroclinic 3D Shallow Water Model," DoD - DEPSCoR (via ONR), \$312K
- 292. R. Luettich (UNC), R. Kolar, B. Vieux, J. Gourley, "The Center for Natural Disasters, Coastal Infrastructure, and Emergency Management," DHS, \$699K
- 293. D. Papavassiliou, M. Zaman, H. Neeman, "Integrated, Scalable MBS for Flow Through Porous Media," NSF, \$150K
- 294. Y. Wang, P. Mukherjee, "Wavelet based analysis of WMAP data," NASA, \$150K
- 295. E. Mansell, C. L. Ziegler, J. M. Straka, D. R. MacGorman, "Numerical modeling studies of storm electrification and lightning," \$605K

OSCER-FACILITATED FUNDING TO DATE:

\$447M total, \$205M to OU

OSCER State of the Center Address

Wed Sep 21 2016

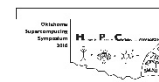

External Research Grants (cont'd)

296. K. Brewster, J. Gao, F. Carr, W. Lapenta, G. Jedlovec, "Impact of the Assimilation of AIRS Soundings and AMSR-E Rainfall on Short Term Forecasts of Mesoscale Weather," NASA, \$458K
297. R. Wheeler, T. Click, "National Institutes of Health/Predocctoral Fellowships for Students with Disabilities," NIH/NIGMS, \$80K
298. K. Pathasarathy, D. Papavassiliou, L. Lee, G. Newman, "Drag reduction using surface-attached polymer chains and nanotubes," ONR, \$730K
299. D. Papavassiliou, "Turbulent transport in non-homogeneous turbulence," NSF, \$320K
300. C. Doswell, D. Weber, H. Neeman, "A Study of Moist Deep Convection: Generation of Multiple Updrafts in Association with Mesoscale Forcing," NSF, \$430K
301. D. Papavassiliou, "Melt-Blowing: Advance modeling and experimental verification," NSF, \$321K
302. R. Kol,ar et al., "A Coupled Hydrodynamic/Hydrologic Model with Adaptive Gridding," ONR, \$595K
303. D. Papavassiliou, "Scalar Transport in Porous Media," ACS-PRF, \$80K
304. M. Xue, F. Carr, A. Shapiro, K. Brewster, J. Gao, "Research on Optimal Utilization and Impact of Water Vapor and Other High Resolution Observations in Storm-Scale QPF," NSF, \$880K.
305. J. Gao, K. Droegemeier, M. Xue, "On the Optimal Use of WSR-88D Doppler Radar Data for Variational Storm-Scale Data Assimilation," NSF, \$600K.
306. K. Mish, K. Muraleetharan, "Computational Modeling of Blast Loading on Bridges," OTC, \$125K
307. V. DeBrunner, L. DeBrunner, D. Baldwin, K. Mish, "Intelligent Bridge System," FHWA, \$3M
308. D. Papavassiliou, "Scalar Transport in Porous Media," ACS-PRF, \$80K
309. Y. Wang, P. Mukherjee, "Wavelet based analysis of WMAP data," NASA, \$150K
310. R. Wheeler et al., "Testing new methods for structure prediction and free energy calculations (Predocctoral Fellowship for Students with Disabilities)," NIH/NIGMS, \$24K
311. L. White et al., "Modeling Studies in the Duke Forest Free-Air CO2 Enrichment (FACE) Program," DOE, \$730K

OSCER-FACILITATED FUNDING TO DATE:
\$447M total, \$205M to OU

OSCER State of the Center Address

Wed Sep 21 2016

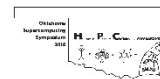

External Research Grants (cont'd)

- 312. Neeman, Severini, "Cyberinfrastructure for Distributed Rapid Response to National Emergencies", NSF, \$132K
- 313. Neeman, Roe, Severini, Wu et al., "Cyberinfrastructure Education for Bioinformatics and Beyond," NSF, \$250K
- 314. K. Milton, C. Kao, "Non-perturbative Quantum Field Theory and Particle Theory Beyond the Standard Model," DOE, \$150K
- 315. J. Snow, "Oklahoma Center for High Energy Physics", DOE EPSCoR, \$3.4M (total), \$169K (LU)
- 316. M. Xue, F. Kong, "OSSE Experiments for airborne weather sensors," Boeing, \$90K
- 317. M. Xue, K. Brewster, J. Gao, A. Shapiro, "Storm-Scale Quantitative Precipitation Forecasting Using Advanced Data Assimilation Techniques: Methods, Impacts and Sensitivities," NSF, \$835K
- 318. Y. Kogan, D. Mechem, "Improvement in the cloud physics formulation in the U.S. Navy Coupled Ocean-Atmosphere Mesoscale Prediction System," ONR, \$889K
- 319. G. Zhang, M. Xue, P. Chilson, T. Schuur, "Improving Microphysics Parameterizations and Quantitative Precipitation Forecast through Optimal Use of Video Disdrometer, Profiler and Polarimetric Radar Observations," NSF, \$464K
- 320. T. Yu, M. Xue, M. Yeay, R. Palmer, S. Torres, M. Biggerstaff, "Meteorological Studies with the Phased Array Weather Radar and Data Assimilation using the Ensemble Kalman Filter," ONR/Defense EPSCOR/OK State Regents, \$560K
- 321. B. Wanner, T. Conway, et al., "Development of the www.EcoliCommunity.org Information Resource," NIH, \$1.5M (total), \$150K (OU)
- 322. T. Ibrahim et al., "A Demonstration of Low-Cost Reliable Wireless Sensor for Health Monitoring of a Precast Prestressed Concrete Bridge Girder," OK Transportation Center, \$80K
- 323. T. Ibrahim et al., "Micro-Neural Interface," OCAST, \$135K
- 324. J. Snow, "Langston University High Energy Physics," \$155K (LU)

OSCER-FACILITATED FUNDING TO DATE:

\$447M total, \$205M to OU E M E W

OSCER State of the Center Address

Wed Sep 21 2016



External Research Grants (cont'd)

- 325. L.M. Leslie, M.B. Richman, C. Doswell, "Detecting Synoptic-Scale Precursors Tornado Outbreaks," NSF, \$548K
- 326. L.M. Leslie, M.B. Richman, "Use of Kernel Methods in Data Selection and Thinning for Satellite Data Assimilation in NWP Models," NOAA, \$342K
- 327. J. Gao, K. Brewster, M. Xue, K. Droegemeier, "Assimilating Doppler Radar Data for Storm-Scale Numerical Prediction Using an Ensemble-based Variational Method," NSF, \$200K
- 328. E. Chesnokov, "Fracture Prediction Methodology Based On Surface Seismic Data," Devon Energy, \$1M
- 329. E. Chesnokov, "Scenario of Fracture Event Development in the Barnett Shale (Laboratory Measurements and Theoretical Investigation)," Devon Energy, \$1.3M
- 330. M. Xue, K. Brewster, J. Gao, "Study of Tornado and Tornadoic Thunderstorm Dynamics and Predictability through High-Resolution Simulation, Prediction and Advanced Data Assimilation," NSF, \$780K
- 331. A. Striolo, "Heat Transfer in Graphene-Oil Nanocomposites: A Molecular Understanding to Overcome Practical Barriers." ACS Petroleum Research Fund, \$40K
- 332. D.V. Papavassiliou, "Turbulent Transport in Anisotropic Velocity Fields," NSF, \$292.5K
- 333. D. Oliver, software license grant, \$1.5M
- 334. R. Broughton et al, "Assembling the Eutelost Tree of Life – Addressing the Major Unresolved Problem in Vertebrate Phylogeny," NSF, \$3M (\$654K to OU)
- 335. A. Fagg, "Development of a Bidirectional CNS Interface or Robotic Control," NIH, \$600K
- 336. M. Xue, J. Gao, "An Investigation on the Importance of Environmental Variability to Storm-scale Radar Data Assimilation," NSSL, \$72K
- 337. JV. Sikavistsas and D.V. Papavassiliou , "Flow Effects on Porous Scaffolds for Tissue Regeneration," NSF, \$400K
- 338. P. Skubic, M. Strauss, et al., "Experimental Physics Investigations Using Colliding Beam Detectors at Fermilab and the LHC," DOE, \$503K

OSCER-FACILITATED FUNDING TO DATE:

\$447M total, \$205M to OU E M E W

OSCER State of the Center Address

Wed Sep 21 2016



External Research Grants (cont'd)

- 339. Y. Wang, "Science for the Euclid Mission", NASA/JPL, \$52K (2016)
- 340. D. LaDue, K. Kloesel, "EPSCoR Funded Participant in the National Weather Center Research Experiences for Undergraduates Program," Oklahoma EPSCoR, \$9K
- 341. V. Sikavitsas, D. Papavassiliou, "The influence of fluid shear forces, oxygen and nutrient mass transport in the development of bone grafts in perfusion bioreactors," OCAST,, \$45K
- 342. D. Schmidtke, D. Papavassiliou, "Development of a Miniature Right Heart Support Device," NIH, \$347K
- 343. D. Resasco, D. Papavassiliou, "Interfacially active SWNT/silica nanohybrids," Advanced Energy Consortium, \$688K
- 344. B. L. Cheong, T.-Y. Yu, R. .D. Palmer, "Instrumental Support for the Winter Experiment Campaign," SELab Inc, \$215K
- 345. E. Bridge, "CAREER: Unwrapping the Migratory Gene Package," NSF, \$760K
- 346. E. Bridge, "The Electronic Transponder Analysis Gateway (ETAG): An Animal Behavior Observatory," NSF, \$315K
- 347. E. Bridge, "An Open-Source Radio Frequency Identification System for Animal Monitoring," NSF, \$331K
- 348. R. McPherson, E. White, M. Shafer, D. Rosendahl, M. Richman, "Trends in cold temperature extremes and winter weather for the SPTC region," USDOT, \$132K
- 349. R. Palmer, B. Cheong, C. Fulton, J. Salarzar, M. Yeary, T.-Y. Yu, Y. Zhang,. "Meeting the Technical Challenges of the Multi-Mission Phased Array Radar," NOAA, \$1.65M
- 350. M. J. McInerney, L. Krumholz, Bioremediation of Chromium and Arsenic from Industrial Wastewater," Nat'l Academies of Science, \$162K
- 351. M. Coniglio (PI), C. Doswell III, R. J. Trapp
- 352. "Improved understanding of convective-storm predictability and environment feedbacks from observations during the Mesoscale Predictability Experiment (MPEX)," NSF, \$272K
- 353. Y. Kogan, "Parameterization of Cumulus Convective Cloud Systems in Mesoscale Forecast Models," ONR, \$267K
- 354. S. Schroeder, "Predicting Viral RNA Structures, Function, and Drug Targets from Sequence," OCAST, \$145K

OSCER-FACILITATED FUNDING TO DATE:

\$447M total, \$205M to OU E M E W

OSCER State of the Center Address

Wed Sep 21 2016

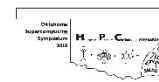

External Research Grants (cont'd)

355. L. Ding, "NRI-Small: Robot Assistants for Promoting Crawling and Walking in Children at Risk of Cerebral Palsy," NSF, \$1.135M
356. M. Elwood Madden, G. Soreghan, A. Callaghan, J. Volz, M. Nannny, "Acquisition of a High Resolution Raman Mapping Microscope," NSF, \$294K
357. E. Baron, "Collaborative Research: Three-Dimensional Simulations of Type Ia Supernovae Constraining Models with Observations," NSF, \$26K
358. H. Neeman, K. Brewster, A. McGovern, H. Severini, T. Yu, M. Atiquzzaman, G. Creager, B. George, Z. Gray, S. Radhakrishnan, P. Skubic, M. Strauss, X. Xiao, M. Xue, "A Model for Advanced Cyberinfrastructure Research and Education Facilitators," NSF, \$400K
359. E. Lemley, G. Qian, "MRI: Acquisition of a High Performance Computing Cluster for Research at a Predominantly Undergraduate Institution," NSF, \$305K
360. R. Floyd, J. Pei, "Understanding the Behavior of Prestressed Concrete Girders after Years of Service," OK DOT, \$327K
361. G. Zhang, S. Arani, "Polarimetric Phased Array Radar Research in Support for MPAR Strategy," NOAA, \$438K
362. A. Fierro, M. DeMaria, E. Mansell, C./ Ziegler, D. MacGorman, A. Schumacher, R. Brummer. "Using total lightning data from GLM/GOES-R to improve real-time tropical cyclone genesis and intensity forecasts," NOAA, \$268K (\$123K to OU)
363. U. Hansmann, "Folding, Mis-folding and Aggregation of Proteins," NIH, \$887K
364. G. R. Keller, S. Holloway, D. Devegowda, K. Crain, A. Holland, A. Ghassemi, "4D Integrated Study Using Geology, Geophysics, Reservoir Modeling and Rock Mechanics to Development Assessment Models for Potential Induced Seismicity Risk,," \$1.478M
365. J. Gao, D. Stensrud, X. Wang, "Assimilation of Doppler Radar Data with an Ensemble-based Variational Method for Storm-scale NWP," NSF, \$481K
366. M. Soe (RSU), "Unitary Qubit Lattice Algorithms for Quantum Turbulence with Non-Abelian Vortices," NSF, \$75K,

OSCER-FACILITATED FUNDING TO DATE:

\$447M total, \$205M to OU

OSCER State of the Center Address

Wed Sep 21 2016

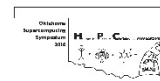

External Research Grants (cont'd)

- 367. J. Cruz, "Two-Dimensional Channel Modeling, Detection and Coding for Shingled Magnetic Recording," NSF, \$419K,
- 368. J. Shaffer, "Laser Stabilization System for Rydberg Atom Physics," Army Research Office, \$75K

OSCER-FACILITATED FUNDING TO DATE:

\$447M total, \$205M to OU

OSCER State of the Center Address

Wed Sep 21 2016



External Funding Summary

- External research funding facilitated by OSCER (Fall 2001- Fall 2016): **\$447M total, \$205M to OU (60%)**
- Funded projects: **OVER 360**
- **134** OU faculty and staff in **21** academic departments and **6** non-academic units
- Comparison: Fiscal Year 2002-16 (July 2001 – June 2016):
OU Norman externally funded research expenditure: \$1.72B

Since being founded in fall of 2001, OSCER has enabled research projects comprising almost

1 / 7 of OU Norman's total externally funded research expenditure, with an 8-to-1 return on investment.



OSCER State of the Center Address
Wed Sep 21 2016



Publications Facilitated by Research IT

- Publications facilitated by Research IT resources

- **2016: 180** (so far)
- 2015: 203
- 2014: 249
- 2013: 257
- 2012: 291
- 2011: 184
- 2010: 144
- 2009: 112
- 2008: 114
- 2007: 77
- 2006: 96
- 2005: 71
- 2004: 32
- 2003: 12
- 2002: 10
- 2001: 3

TOTAL SO FAR: 2053 publications

http://www.oscer.ou.edu/papers_from_rounds.php

Includes 47 MS theses, 40 PhD dissertations.



OSCER State of the Center Address
Wed Sep 21 2016



Advanced
Cyberinfrastructure
Research & Education

Facilitators
2015-17

History

- March 2012: Clemson U creates “Condo of Condos” initiative.
- Apr 2013: Clemson U submits “Condo of Condos” proposal, including ACI-REFs and networking hardware:
13 institutions, 4 years, \$33M+
- March 2015: Proposal partially funded, ACI-REFs only:
6 institutions (not OU), 2 years, \$5.3M
- Apr 2015: OU submits ACI-REF CC*IIE proposal.
- Sep 2015: NSF announces OU ACI-REF grant.
 - 2 years of 1.0 FTE (Oct 2016 – Sep 2016)
 - 2 summer workshops (2016, 2016) on how to be an ACI-REF



What's an ACI-REF?

- An Advanced Cyberinfrastructure – Research & Education Facilitator (ACI-REF) works directly with research teams to adopt advanced cyberinfrastructure into their research and education.
- OSCER personnel have been providing a low-intensity version of this service since the beginning.
- OU Informatics personnel have been providing a high intensity version since fall 2010.
- OU's ACI-REF FTE focuses on high end networking, especially SDN via OFFN.



OSCER State of the Center Address
Wed Sep 21 2016



ACI-REF Grant Objectives #1

- Data-Intensive Research Facilitation: Via Software Defined Networking (SDN) across OFFN, facilitate end-to-end management, by researchers, of high bandwidth/high performance data flows through a distributed hierarchy of open standards tools, providing researchers with a new layer of transparency into network transport at OU, among OneOCII institutions, and with ACI-REF members.
- Oklahoma ACI-REF project: Lead and facilitate adoption of the ACI-REF approach across Oklahoma, leveraging extant and emerging capabilities within OneOCII.



OSCER State of the Center Address
Wed Sep 21 2016

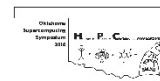

ACI-REF Grant Objectives #2

- National training regime: Provide a “virtual residency” program for Campus CI Engineers and other ACI-REFs, open to not only CC*IIE awardees and ACI-REF members but any institution that needs.
- Research Experiences for Undergraduates (REU)
Sites/Supplements: Foster undergraduate research at OU via a culture of integrating REU sites and supplements into STEM research, including by all research themes on the ACI-REF grant.



OSCAR State of the Center Address
Wed Sep 21 2016



Research Projects Part 1

- High Energy Physics
 - also on on DOE EPSCoR, C2, PetaStore, OFFN
 - 8 Gbps
 - \$1.7M current, \$1M pending/planned
 - 7 faculty, 2 staff, 4 postdocs, 9 grad students
- Spring Realtime Storm Forecasting Experiment (CAPS)
 - also on C2, PetaStore, OFFN
 - 12 Gbps
 - \$2.5M current, \$1M pending/planned
 - 6 faculty, 10 staff, 20 grad students
- Weather Radar (ARRC)
 - also on PetaStore, OFFN
 - 1.9 Gbps
 - \$10M current, \$30M pending/planned
 - 16 faculty, 7 staff, 16 postdocs, ~60 grad students, ~10 undergrads



OSCAR State of the Center Address

Wed Sep 21 2016



Research Projects Part 2

- Tornado Models (IDEA)
 - also on EPSCoR RII Track-2, PetaStore, OFFN
 - 0.6 Gbps
 - \$600K current, \$500K pending/planned
- Warn on Forecast (CIMMS): NEW!
 - 0.5 Gbps
 - \$677K current
 - 12 staff, 4 postdocs, 3 grad students
- Ecological Informatics (EOMF)
 - also on EPSCoR RII Track-2, OFFN
 - 0.2 Gbps
 - \$5M current, \$8M pending/planned
 - 1 faculty, 3 staff, 3 postdocs, 7 grad students, 1 undergrad

Research Projects Part 3

- Data Networks (CS)
 - also on OFFN
 - \$720K current
 - 2 faculty, 3 grad students
- TOTALS
 - 23 Gbps
 - \$21 current, \$40M pending/planned
 - 33 faculty, 34 staff, 27 postdocs, ~108 grad students, ~14 undergrads



OSCER State of the Center Address
Wed Sep 21 2016

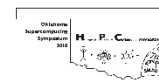

ACI-REF

Virtual Residency

Reviewer Comments

- “This energetic, detailed and ambitious proposal from the University of Oklahoma deserves the highest priority for support. ... There are no major weaknesses in the proposal and many strengths. ...”
- “The broader impacts are nicely defined in terms of ... the idea of a residency program A residency program and enhancement of undergraduate research are strong enhancements to the proposal. ...”
- “This is one of the better proposals regarding ... additional outreach via the budgeted virtual residency program. ...”



OSCER State of the Center Address
Wed Sep 21 2016



ACI-REF Virtual Residency: Why?

- CI Facilitators have strong experience within their discipline (often non-CS).
- Most CI Facilitators and CI Engineers haven't been faculty.
- Sometimes little or no research experience (especially for SDN-focused CI Engineers).
- Even if strong research background, typically little or no experience with research outside their own discipline.
- When we started the Virtual Residency in 2015, there were no local, regional or national programs to teach people how to be an ACI-REF.
- In the olden days, you could take your time learning how to do this -- but not anymore



OSCER State of the Center Address
Wed Sep 21 2016



Lots of Interest

■ Proposal

- Polled CC-NIE awardees, MRI CI awardees, Minority Serving Institutions.
- Interest expressed from 33 institutions in 23 states & territories expressed interest, including 3 MSIs and 19 institutions in 13 EPSCoR jurisdictions, and 7 non-PhD-granting institutions.

■ Applications

- 2015: over 60 applicants from 49 institutions in over 30 states and territories.
- 2016: 90 applicants from 63 institutions in 34 US states plus 3 other countries (Canada, India, Nigeria).



OSCER State of the Center Address
Wed Sep 21 2016



Lots of Interest (cont'd)

- **Participants: 128 total**

- 2015: 50 total from 38 institutions in 26 states and territories (28 onsite and 22 offsite via videoconferencing), including:
 - 21 institutions in 12 EPSCoR jurisdictions;
 - 5 Minority Serving Institutions;
 - 5 non-PhD-granting institutions.
- 2016: 99 total from 68 institutions in 33 states plus Canada and Nigeria (43 onsite, 56 offsite), including:
 - 27 attendees from 20 institutions in 13 EPSCoR jurisdictions;
 - 10 Minority Serving Institutions;
 - 13 non-PhD-granting institutions.



OSCER State of the Center Address
Wed Sep 21 2016



What Did We Want to Teach?

- Teach how to work with researchers who are using CI.
 - Teach how to talk to them.
 - Teach how to help them.
- Teach how to contribute to, and ultimately to lead, grant proposals.
 - Some of them already knew how to do this, so their job was to help us help the rest.
- Science DMZ Track
 - Teach how to manage a Science DMZ.
- Computational Science & Engineering Track
 - Get some practice working with researchers.



OSCER State of the Center Address
Wed Sep 21 2016



What Weren't We Trying to Do?

- On the Computational & Data-enabled Science & Engineering track, we **WEREN'T** trying to teach a lot of technical content.
 - People can learn that from other sources.
- Instead, our goal was to teach them the **PROFESSION** of ACI-REF.
- To get them thinking about this, we had each do a 5-minute mini-project/talk on something they were going to do at their home institution, based on what they'd gotten from the workshop.



OSCER State of the Center Address
Wed Sep 21 2016



What Was the Hidden Agenda?

- Our real goal was to prepare for an upcoming transition to:
 - more need for this kind of skilled workforce, but
 - fewer people who know how to do it, with
 - no mechanism to prepare a sufficiently large cohort.
- Some of the participants already knew how to do this.
 - But it took a very long time to learn on their own.
 - To keep up with demand, the community needs us to streamline the process so that new ACI-REFs can become fully productive quickly.
- Today's ACI-REFs are tomorrow's CI leaders.



OSCER State of the Center Address
Wed Sep 21 2016



ACI-REF Workshop Agenda 2015

- **SUNDAY (evening pizza party)**
 - Welcome and virtual residency overview
 - Introduction to Research
Cyberinfrastructure consulting
 - How to Give a CI Tour
- **MONDAY**
 - Early AM: Effective Communication:
How to Talk to Researchers about Their
Research
 - Computational and Data-enabled Science
& Engineering (CDS&E) Track
 - Mid AM: Deploying Community Codes
 - Early PM: Real user presents their
CDS&E research
 - SCIENCE DMZ Track
 - Mid AM: OpenFlow - Lecture
 - Early PM: OpenFlow - Lab
 - Mid PM: CI User Support
- **TUESDAY**
 - Very Early AM: Project Guidelines
 - Early AM: Faculty: Tenure, Promotion,
Reward System
 - CDS&E Track
 - Mid AM: Benchmarking & Tuning
 - Early PM: Real users present CDS&E research
 - Mid PM: Real users: CI consulting practicum
("speed dating")
 - SCIENCE DMZ Track
 - Mid AM: Exploring Open Daylight - Lecture
 - Early PM: Exploring Open Daylight - Lab
 - Mid PM: Real users' high bandwidth research
- **WEDNESDAY**
 - Early AM: Using Videoconferencing and
Collaboration Technologies for Consulting
 - Mid AM: Writing Grant Proposals
 - PM: BREAK (free time)



OSCAR State of the Center Address
Wed Sep 21 2016



ACI-REF Workshop Agenda

■ THURSDAY

- Early AM: The Shifting Landscape of CI Funding Opportunities
- CDS&E Track
 - Mid AM: Finding and Provisioning Remote Resources (XSEDE, OSG)
 - Early PM: Real users present CDS&E research (“speed dating”)
 - Mid PM: Catch-up on unfinished talks
- SCIENCE DMZ Track
 - Mid AM: The Software in SDN - Lecture
 - Early PM: The Software in SDN - Lab
 - Mid PM: Real users' high bandwidth research

■ FRIDAY

- Early AM: So You Want to Write a CI Proposal
- Mid AM: Panel: Stories from the Trenches
- Early PM: Project work time
- Mid PM: Project work time
- Late PM: Project presentations from early departers

■ SATURDAY

- AM: Project presentations



OSCER State of the Center Address
Wed Sep 21 2016



Theme #1

1. How to Understand and Work with Real Researchers

- Introduction to Research Cyberinfrastructure consulting
- How to Give a CI Tour
- Effective Communication: How to Talk to Researchers about Their Research
- Real User Presents Their Research
- CI User Support
- Faculty: Tenure, Promotion, Reward System
- Real users: CI consulting practicum (“speed dating”)
- Panel: Stories from the Trenches



OSCER State of the Center Address
Wed Sep 21 2016



Theme #2

2. Technical Content

- Deploying Community Codes
- Benchmarking & Tuning
- Using Videoconferencing and Collaboration Technologies for Consulting
- Science DMZ Content
 - OpenFlow
 - Exploring Open Daylight
 - The Software in Software Defined Networking



OSCER State of the Center Address
Wed Sep 21 2016

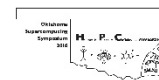

Themes #3-4

3. Proposal Writing

- Writing Grant Proposals
- The Shifting Landscape of CI Funding Opportunities
- So You Want to Write a CI Proposal
- The Cyberinfrastructure Milieu
 - Finding and Provisioning Remote Resources (XSEDE, OSG)



OSCER State of the Center Address
Wed Sep 21 2016



Newly Funded Workshop Grant!

(Just awarded last week)

Henry Neeman, PI

Cyberinfrastructure Leadership Academy

University of Oklahoma

Norman, Oklahoma

<http://www.oscer.ou.edu/>

hneeman@ou.edu



- **Senior Cyberinfrastructure leaders** are retiring and taking their knowledge, experience and wisdom with them. We need to capture this quickly.
- **Emerging midcareer CI leaders** are excellent at responding to national needs and serving their institutions' researchers, but need to learn how to **shape the national CI agenda**.
- **Goals** of this workshop in **bringing these two groups together**:
 - **Transfer knowledge, experience and especially wisdom** from senior CI leaders to emerging CI leaders, in order to enable emerging CI leaders to shape the national research CI landscape.
 - **Initiate mentoring relationships** between senior CI leaders and emerging CI leaders, in order to foster longer term professional development.
 - **Establish peer mentoring** among emerging CI leaders, in order to prepare and position them for national leadership, as senior CI leaders reduce their day to day engagement.
- **National Strategic Computing Initiative**: This workshop focus is a key aspect of the NSF's **workforce development** mission within NSCI.

Acknowledgements

Portions of this material are based upon work supported by the National Science Foundation under the following grants:

- Grant No. EPS-0814361, “Building Oklahoma's Leadership Role in Cellulosic Bioenergy”
- Grant No. EPS-1006919, “Oklahoma Optical Initiative”
- Grant No. OCI-1039829, “MRI: Acquisition of Extensible Petascale Storage for Data Intensive Research”
- Grant No. OCI-1126330, “Acquisition of a High Performance Compute Cluster for Multidisciplinary Research”
- Grant No. ACI- 1229107, “Acquisition of a High Performance Computing Cluster for Research and Education”
- Grant No. EPS-1301789, “Adapting Socio-ecological Systems to Increased Climate Variability”
- Grant No. ACI-1341028, “OneOklahoma Friction Free Network”
- Grant No. ACI-1429702, “Acquisition of a High Performance Computing Cluster for Research at a Predominantly Undergraduate Institution”
- Grant No. ACI-1440774, “Leveraging Partnerships Across the Great Plains to Build Advanced Networking and CI Expertise”
- Grant No. ACI-1440783, “A Model for Advanced Cyberinfrastructure Research and Education Facilitators”



OSCER State of the Center Address
Wed Sep 21 2016



Acknowledgements

Dell provided seed systems for the OU Research Cloud (“OURcloud”) and the OU Science DMZ.



OSCER State of the Center Address
Wed Sep 21 2016



Symposium 2016 Sponsors: Thank You!

- Academic sponsor (1)
 - Great Plains Network
- Industry sponsors (17/18)
 - Platinum (1): Intel + HP
 - Gold (7): Arista Networks, **Brocade**/Lumenate, Dell, Mellanox Technologies, NVIDIA, **Quantum**, **Qumulo**
 - Silver (4): Cray, DataDirect Networks, SGI, Spectra Logic
 - Bronze (5/6): Adaptive Computing, Advanced Clustering Technologies, Aspen Systems, **Penguin**, **Pinnacle**/EMC

Thank you all! Without you, the Symposium couldn't happen. Over the past 14 Symposia, we've had a total of 84 companies as sponsors – and more than half have repeated (or were acquired by/merged with other sponsors).



OSCER State of the Center Address
Wed Sep 21 2016



Symposium 2016 Sponsors: Thank You!

- Academic sponsor (1)
 - Great Plains Network
- Industry sponsors (17/18)
 - Platinum/Lunch (1): Hewlett-Packard Enterprise
 - Gold (1): Dell EMC
 - Silver (8/10): DDN Storage, Dell EMC, Intel, Lenovo, Lumentate/Brocade, Mellanox Technologies, Quantum, SGI, Spectra Logic/**Advanced Systems Group**
 - Bronze (4): Adaptive Computing, Advanced Clustering Technologies, NVIDIA, Penguin

Thank you all! Without you, the Symposium couldn't happen. Over the past 14 Symposia, we've had a total of 85 companies as sponsors – and just over half have repeated (or were acquired by/merged with other sponsors).



OSCER State of the Center Address
Wed Sep 21 2016



Thanks!

- OU IT
 - OU CIO/VPIT Loretta Early
 - Symposium committee: Dana Brunson (OSU), Debi Gentis (OU)
 - Symposium coordinator: Debi Gentis
 - Sponsorship coordinator: Chance Grubb
 - OSCER Operations Team: Dave Akin, Patrick Calhoun, Kali McLennan, Jason Speckman, Brett Zimmerman
 - All of the OU IT folks who helped put this together
- CCE Forum
 - Jake Maurer, Kristin Livingston
 - The whole Forum crew who helped put this together



OSCER State of the Center Address
Wed Sep 21 2016



Thanks: Plenary Speakers

- Dan Stanzione, Texas Advanced Computing Center, University of Texas at Austin
- Suresh Marru, Indiana University (lightning talk)
- Vas Vasiliadis, Globus/University of Chicago
- Stephen Wheat, Hewlett-Packard Enterprise (Platinum/Lunch sponsor)



OSCER State of the Center Address
Wed Sep 21 2016



Thanks: Gold Sponsor Speaker

- Nishanth Dandapanthula, Dell Technologies



OSCER State of the Center Address
Wed Sep 21 2016



Thanks: Breakout Speakers

1. Marcus A. Bond, Southeast Missouri State University
2. Dana Brunson, Oklahoma State University
3. Shane Corder, Children's Mercy Kansas City
4. Nishanth Dandapanthula, Dell Technologies
5. Brady Deetz, Laureate Institute for Brain Research
6. Karl Frinkle, Southeastern Oklahoma State University
7. Kyle Hutson, Kansas State University
8. Mark Laufersweiler, University of Oklahoma
9. Evan Lemley, University of Central Oklahoma
10. Suresh Marru, Indiana University
11. Perdeep K. Mehta, The Samuel Roberts Noble Foundation
12. Mike Morris, Southeastern Oklahoma State University
13. Horst Severini, University of Oklahoma
14. Nathan Sloat, University of Oklahoma
15. Neal N. Xiong, Southwestern Oklahoma State University



OSCAR State of the Center Address
Wed Sep 21 2016

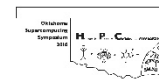

Thanks!

To all of you for participating, and to those many of you who've shown us so much loyalty over the past 14 years.



OSCER State of the Center Address
Wed Sep 21 2016



Such a bargain!

- If you want your t-shirt and your pen/flashlight/laser pointer, all you have to do is give us a completed evaluation form!
- It's that easy!
- What a bargain!



OSCER State of the Center Address
Wed Sep 21 2016



To Learn More

<http://www.oscer.ou.edu/>

<http://oneocii.okeyscores.org/>



OSCER State of the Center Address
Wed Sep 21 2016



**Thanks for your
attention!**

Questions?

Supplementary Materials



Oklahoma
Cyberinfrastructure
Initiative

2008-13

OK Cyberinfrastructure Initiative

- All academic institutions in Oklahoma are eligible to sign up for free use of OU's and OSU's centrally-owned CI resources.
- Other kinds of institutions (government, non-governmental) are eligible to use, though not necessarily for free.
- Everyone can participate in our CI education initiative.
- The Oklahoma Supercomputing Symposium, our annual conference, continues to be offered to all.
- Triggered by OK's NSF EPSCoR RII Track-1 2008-13.



OSCER State of the Center Address
Wed Sep 21 2016



OneOklahoma Cyberinfrastructure Initiative

OCII Goals

- **Reach** institutions outside the mainstream of advanced computing.
- **Serve** every higher education institution in Oklahoma that has relevant curricula.
- **Educate** Oklahomans about advanced computing.
- **Attract** underrepresented populations and institution types into advanced computing.



OSCER State of the Center Address
Wed Sep 21 2016



OneOCII Strategy

- OneOCII doesn't exactly have a strategy; it'd be more accurate to say we have an approach:
 - Every CI project in the state is part of the larger whole.
 - Each new project advances a subset of OneOCII.
 - Not all parts of OneOCII advance at the same time.
 - Everyone works together on everything.



OSCAR State of the Center Address
Wed Sep 21 2016



OCII Service Methodologies Part 1

- **Access (A)**: to supercomputers and related technologies (20 OK academic institutions to date).
- **Dissemination (D)**: Oklahoma Supercomputing Symposium – annual advanced computing conference (25 OK academic institutions to date).
- **Education (E)**: “Supercomputing in Plain English” (SiPE) workshop series: 11 talks about advanced computing, taught with stories, analogies and play rather than deep technical jargon. Have reached 248 institutions (academic, government, industry, nonprofit) in 47 US states and territories and 10 other countries (14 OK academic institutions to date).



OSCER State of the Center Address
Wed Sep 21 2016



OCII Service Methodologies Part 2

- **Faculty/Staff Development (F)**: Workshops held at OU and OSU on advanced computing and computational science topics, sponsored by the National Computational Science Institute, the SC supercomputing conference series, the Linux Clusters Institute, the Virtual School for Computational Science & Engineering. Oklahoma is the only state to have hosted multiple events sponsored by each of these (18 OK academic to date).
- **Outreach (O)**: “Supercomputing in Plain English” (SiPE) overview talk (24 OK academic to date).
- **Proposal Support (P)**: Letters of commitment for access to OCII resources; collaborations with OCII lead institutions (4 OK academic, 1 nongovernmental).



OSCER State of the Center Address
Wed Sep 21 2016

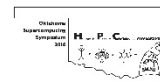

OCII Service Methodologies Part 3

- **Technology (T)**: Got or helped get technology (e.g., network upgrade, mini-supercomputer, hi def video camera for telepresence) for that institution (14 OK academic to date).
- **Workforce Development (W)** – (36 OK academic)
 - Oklahoma Information Technology Mentorship Program (OITMP)
 - “A Day in the Life of an IT Professional” presentations to courses across the full spectrum of higher education.
 - Job shadowing opportunities and direct mentoring of individual students.
 - Institution Types: high schools, career techs, community colleges, regional universities, PhD-granting universities.
- Special effort to reach underrepresented populations: underrepresented minorities, non-PhD-granting, rural



OSCER State of the Center Address
Wed Sep 21 2016



OCII Institution Profile

To date, OCII has served 100 Oklahoma institutions, agencies and organizations:

- 52 OK academic (2 more booked this semester)
- 48 OK non-academic



OSCER State of the Center Address
Wed Sep 21 2016



OCII Institution Profile

To date, OCII has served 100 Oklahoma institutions, agencies and organizations:

- 52 OK academic
 - Universities & Colleges
 - 3 comprehensive PhD-granting
 - 20 regional non-PhD-granting
 - Community Colleges: 10
 - Career techs: 13
 - Secondary schools: 4
 - Public school systems: 2
- 48 OK non-academic



OSCER State of the Center Address
Wed Sep 21 2016



OCII Institution Profile

So far, OCII has served:

- 52 OK academic
 - 9 Minority Serving Institutions
 - 15 other institutions with above state average and national average for one or more underrepresented minorities
- 48 OK non-academic

Minority Serving Institutions

- Oklahoma's only Historically Black College or University
 - Langston U (Langston)
- Native American Serving Non-tribal Institutions
 - East Central U (Ada)
 - Northeastern Oklahoma A&M College (Miami)
 - Northeastern State U (Tahlequah)
 - Southeastern Oklahoma State U (Durant)
- Tribal Colleges
 - College of the Muscogee Nation (Okmulgee)
 - Comanche Nation College (Lawton)
 - Pawnee Nation College (Pawnee)
- Other Minority Serving Institution
 - Bacone College (Muskogee)

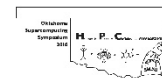

OCII Institution Profile

To date, OCII has served 100 Oklahoma institutions, agencies and organizations:

- 52 OK academic institutions
- 48 OK non-academic organizations
 - 16 commercial
 - 19 government
 - 2 military
 - 11 non-governmental



OSCAR State of the Center Address
Wed Sep 21 2016



OCII Academic Institutions

1. **Bacone College (MSI, 25.0% AI, 29.8% AA): T**

2. **Cameron U (16.6% AA): A, D, E, F, O, T, W**

Taught advanced computing course using OSCER's supercomputer (multiple times).

3. Canadian Valley Tech Center: W

4. Chisholm Trail Tech Center: W

5. **College of the Muscogee Nation (Tribal): O, T**

6. **Comanche Nation College (Tribal): D, O, T**

7. DeVry U Oklahoma City: D, F, O

8. **East Central U (NASNI, 16.9% AI, rural): A, D, E, F, O, P, T, W**

Taught advanced computing course using OSCER's supercomputer.

9. **Eastern Oklahoma State College (24.9% AI): W**

10. Eastern Oklahoma County Tech Center: W

11. Elgin Middle School: O (tour only)

12. Francis Tuttle Tech Center: D, T, W

13. **Gordon Cooper Tech Center (13.5% AI, nonmetro): D, O, W**

14. **Great Plains Tech Center (11.5% AI): W**

15. **Kiamichi Tech Center (18.5% AI): T, W**

16. **Langston U (HBCU, 77.2% AA): A, D, E, F, O, P, T, W**

NSF Major Research Instrumentation grant for supercomputer awarded in 2012.

Note: Langston U (HBCU), East Central U (NASNI) and U Central Oklahoma are the only non-PhD-granting institutions to have benefited from every category of service that OCII provides.

Average: ~3 (mean 3.5, median 3, mode 1)

AA = African American (7.7% OK population, 13.2% US population)

AI = American Indian (9.0% OK, 1.2% US)

H = Hispanic (9.6% OK, 17.1% US)

ALL = 26.3% OK, 31.5% US

HBCU: Historically Black College or University

NASNI = Native American Serving Non-Tribal Institution

MSI = Minority Serving Institution



OSCER State of the Center Address
Wed Sep 21 2016



OCII Academic (cont'd)

- 17. Lawton Christian School (high school): W
- 18. **Metro Tech Centers (29.3% AA): D**
- 19. Mid-America Tech Center: D, W
- 20. Mid-Del Public Schools: D
- 21. Moore Norman Tech Center: D, W
- 22. **Northeast Tech Center (21.5% AI): W**
- 23. **Northeastern Oklahoma A&M College (NASNI, 22.6% AI): T, W**
- 24. **Northeastern State U (NASNI, 22.4% AI, nonmetro): A, D, E, F, O, T, W**
Taught computational chemistry course using OSCER's supercomputer (multiple).
- 25. Northwestern Oklahoma State U: A, F, O
- 26. Oklahoma Baptist U (nonmetro): A, D, E, F, O, T, W
- 27. Oklahoma Christian U: O, W
- 28. **Oklahoma City Community College: O, T, W**
- 29. Oklahoma City U: A, D, E, F, O, T, W
*Educational Alliance for a Parallel Future mini-supercomputer proposal **funded** in 2011.*
Taught advanced computing course using OSCER's supercomputer (multiple).
- 30. **Oklahoma Panhandle State U (rural): A,D,O,W**
- 31. Oklahoma School of Science & Mathematics (high school): A, D, E, O, W
- 32. Oklahoma State U (PhD): A, D, E, F, O, P, T, W
*NSF Major Research Instrumentation proposal for supercomputer **funded** in 2011.*
- 33. **Oklahoma State U Institute of Technology (community college, 19.9% AI): W**
Average: ~3 (mean 3.5, median 3, mode 1)

AA = African American (7.7% OK population, 13.2% US population)

AI = American Indian (9.0% OK, 1.2% US)

H = Hispanic (9.6% OK, 17.1% US)

ALL = 26.3% OK, 31.5% US

HBCU: Historically Black College or University

NASNI = Native American Serving Non-Tribal Institution

MSI = Minority Serving Institution



OSCER State of the Center Address
Wed Sep 21 2016



OCII Academic (cont'd)

34. Oklahoma State U OKC (16.0% AA, community college): O, T, W
35. Oral Roberts U (17.7% AA): A, F, O, W
36. Panola Public Schools: D
37. Pawnee Nation College (Tribal): T
38. Pontotoc Tech Center (41.6% AI): T, W
39. Rogers State U (12.9% AI): A, D, F, O
Taught computational chemistry course using OSCER's supercomputer.
34. Rose State College (18.0% AA): F, W
35. Sequoia High School (Tribal): W
36. St. Gregory's U (nonmetro): A, D, E, F, O
37. Southeastern Oklahoma State U (NASNI, 21.0% AI, nonmetro): A, D, E, F, O, T, W
Educational Alliance for a Parallel Future mini-supercomputer grant funded in 2011
44. Southern Nazarene U (16.0% AA): A, D, F, O, P, T, W
Taught computational chemistry course using OSCER's supercomputer.
45. Southern OK Tech Center (10.7% AI): T, W
46. Southwestern Oklahoma State U (rural): A, D, E, F, O, T, W
Taught advanced computing course using OSCER's supercomputer (multiple).
47. Tulsa Community College: F, W
48. U Central Oklahoma: A, D, E, F, O, P, T, W
NSF Major Research Instrumentation proposal for supercomputer submitted in 2011-13.
49. U Oklahoma (PhD): A, D, E, F, O, P, T, W
NSF Major Research Instrumentation grant for large scale storage funded in 2010
50. U Phoenix: D
51. U of Science & Arts of Oklahoma (11.7% AI): A, O
52. U Tulsa (PhD): A, D, E, F, O, P, T, W
Taught bioinformatics course using OSCER's supercomputer.

Average: ~3 (mean 3.5, median 3, mode 1)

AA= African American (7.7% OK population, 13.2% US population)

AI = American Indian (9.0% OK, 1.2% US)

H = Hispanic (9.6% OK, 17.1% US)

ALL = 26.3% OK, 31.5% US

HBCU: Historically Black College or University

NASNI = Native American Serving Non-Tribal Institution

MSI = Minority Serving Institution



OSCER State of the Center Address
Wed Sep 21 2016



OCII Non-academic

■ Commercial (16)

1. Andon Corp : D, F
2. Chesapeake Energy Corp : D
3. Creative Consultants : D
4. Fusion Geophysical: D
5. Indus Corp: D, E
6. Information Technologic: D
7. KANresearch: D
8. KeyBridge Technologies: D
9. Lumenate: D
10. OGE Energy Corp: D
11. Perfect Order (now defunct): D
12. PowerJam Production Inc: D
13. Versatile: D
14. Visage Production Inc: D, E
15. Weather Decision Technologies Inc : A
16. Weathernews Americas Inc.: A, D

■ Government (19)

1. City of Duncan: D
2. City of Edmond: D
3. City of Nichols Hills: D
4. City of Tulsa: E
5. NOAA National Severe Storms Laboratory: A, D, E, F
6. NOAA Storm Prediction Center: D
7. NOAA National Weather Service: D
8. NOAA Radar Operations Center: D
9. OK Climatological Survey: D
10. OK Department of Health: D, E
11. OK Department of Human Services: D, E
12. OK Department of Libraries: D
13. OK Department of Mental Health and Substance Abuse Services: D
14. OK Office of State Finance: D
15. Oklahoma State Chamber of Commerce: D
16. OK State Regents for Higher Education: A, D, T
17. OK State Supreme Court: D
18. OK Tax Commission: D
19. Tulsa County Court Services: D



OCII Non-academic (cont'd)

- Military (2)
 1. Fort Sill Army Base: E
 2. Tinker Air Force Base: A, D, E, F, O
- Non-governmental/non-profit (11)
 1. American Society of Mechanical Engineers, Oklahoma City chapter: O
 2. Engineering Club of Oklahoma City: O
 3. Lions Club of Norman OK: O
 4. Lions Club of Shawnee OK: O
 5. Norman Science Café: O
 6. Oklahoma EPSCoR: D
 7. Oklahoma Historical Society: D
 8. Oklahoma Innovation Institute/Tulsa Research Partners: A, D, E, O, P
 9. Oklahoma Medical Research Foundation: A, D, P
 10. Oklahoma Nanotechnology Initiative: D
 11. Samuel Noble Roberts Foundation (**rural**): A, D, E, F, T



OSCER State of the Center Address
Wed Sep 21 2016



OCII Outcomes: Research

- External research funding to OK institutions facilitated by OCII lead institutions (Fall 2001- Summer 2016): **over \$174M**
- Funded projects facilitated: **over 300**
- OK faculty and staff: **over 130** in **~20** academic disciplines
- Publications facilitated: **over 1600**



OSCER State of the Center Address
Wed Sep 21 2016

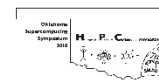

OCII Outcomes: Research

- Specifically needed OCII just to be funded: **over \$43M**
(OneOCII necessary but far from sufficient)
 1. NSF EPSCoR RII Track-1 (2008-13): \$15M to OK
 2. NSF EPSCoR RII Track-1 (2013-18): \$20M to OK (+\$4M Regents)
 3. NSF EPSCoR RII Track-2: \$3M to OK
 4. NSF EPSCoR RII C2: \$1.17M to OK
 5. NSF MRI (OU): \$793K
 6. NSF MRI (OSU): \$908K, \$951K
 7. NSF MRI (Langston U): \$250K
 8. NSF CC-NIE (OU, OSU, LU, OII, OneNet): \$500K
 9. NSF MRI (UCO): \$305K
 10. NSF CC*IIE (OU): \$400K
 11. NSF CC*IIE (GPN, OneNet, others): \$130K
 12. NSF MRI (TU): \$180K

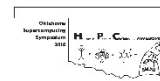

OCII Outcomes: MRI Grants

- NSF Major Research Instrumentation for CI: **over \$2.5M**
 - NSF MRI (OU): \$340K, 2003; \$793K, 2010; submitting 2016
 - NSF MRI (OSU): \$908K, 2011; \$951K, 2016
 - NSF MRI (Langston U): \$250K, 2012
 - NSF MRI (UCO): \$305K, 2014
 - NSF MRI (TU): \$180K, 2016
- How do we stack up (since 2001 when OSCER was founded)?
 - OK: 15.5% of funding, 11% of PIs, 13% of awards
 - OU: 13.5% of funding
 - Among units, IT is 4th in number of awards, 4th in total funding.
 - Among PIs, Neeman is 1st in awards and 1st in funding (13.5%).
 - OSU: 18.5% of funding
 - Langston U: 100% of funding
 - UCO: 70% of funding; Lemley is 1st in funding



OCII Outcomes: Education

Teaching: 9 institutions including 3 MSIs

- Teaching/taught parallel computing using OneOCII resources:
 - Cameron U – multiple times
 - East Central U (NASNI)
 - Oklahoma City U – multiple times
 - Southwestern Oklahoma State U
- Taught parallel computing via LittleFe baby supercomputer and OneOCII resources:
 - Southeastern Oklahoma State U (NASNI) – multiple times
- Taught computational chemistry using OSCER resources:
 - Northeastern State U (NASNI) – multiple times
 - Southern Nazarene U
 - Rogers State U – multiple times
- Taught Bioinformatics using OCII resources:
 - U Tulsa – 2 semester sequence



OSCER State of the Center Address
Wed Sep 21 2016



OCII Outcomes: Resources

7 institutions including 2 MSIs, plus C2 institutions

- NSF Major Research Instrumentation grants: \$1.95M
 - OU: Oklahoma PetaStore, \$793K (in production)
 - Oklahoma State U: Cowboy cluster, \$909K (in production)
 - Langston U: cluster, \$250K (recently deployed)
 - U Central Oklahoma: cluster, \$305K (just awarded)
 - **NEW! U Tulsa**: cluster, \$180K (just awarded)
- LittleFe baby supercomputer grants (\$2500 each)
 - OU: Ron Barnes
 - Oklahoma City U: Larry Sells & John Goulden
 - Southeastern Oklahoma State U: Mike Morris & Karl Frinkle
- Networking: C2 grant: \$1.17M, CC-NIE grant \$500K



OSCER State of the Center Address
Wed Sep 21 2016



OK Optical Initiative (NSF EPSCoR C2)

■ Hardware

- Statewide Ring upgrade: replaced routed mux/demuxes with Reconfigurable Optical Add Drop Modules: much less expensive and much more straightforward to add new 10G circuits.
- Institutional upgrades
 - OU and OSU: cluster upgraded to 10G shared from GigE (10X), then upgraded to 20G (2 x 10G) dedicated (20X), which is connected to Internet2's 100G Innovation Platform backbone.
 - OU: mini-Science DMZ.
 - U Tulsa: upgraded to GigE from 200 Mbps (5X).
 - Samuel Roberts Noble Foundation: (private non-profit research institutions): upgraded to GigE from 45 Mbps for research (22X), 100 Mbps for commodity (2X)

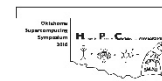

OK Optical Initiative (NSF EPSCoR C2)

- Hardware (continued)
 - Institutional Upgrades (continued)
 - Langston U (Oklahoma's only Historically Black College or University): upgraded to 10G from 100 Mbps (100X) for research.
 - Bacone College (Minority Serving Institution): campus backbone upgraded to 100 Mbps with GigE core from 10 Mbps (10X upgrade).
 - College of the Muscogee Nation (Tribal): network core for new residence hall.
 - Comanche Nation College (Tribal) distance learning system.
 - Pawnee Nation College (Tribal) Internet radio station, distance learning system, campus backbone upgrade to GigE.
 - OK IT Mentorship Program

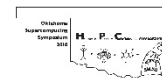

OK Optical Initiative Side Effects

- 100G connection to Internet2's Innovation Platform
- OU+OSU Shared Services initiative: leveraging C2 investments to create enterprise IT collaborations both within and between the institutions.
 - OU Virtual data center – highly robust
 - Virtualized services
 - Substantial savings from shared infrastructure and shared purchasing vehicles.
 - **NOT AT ALL FUNDED BY C2.**
 - But, leverages C2 capabilities – if not for the C2, Shared Services would have had to make the exact same investments in the state ring.



OSCER State of the Center Address
Wed Sep 21 2016

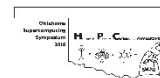

OCII HPC (2008-12)

Just over 40 TFLOPs of HPC capacity across the state:

- OU: 34.5 TFLOPs (internally funded)
- OSU: 6.3 TFLOPs (internally funded)



OSCER State of the Center Address
Wed Sep 21 2016



Education, Outreach, Training, etc

- Education
 - Supercomputing in Plain English (SiPE)
- Outreach
 - SiPE Overview Talk, Cyberinfrastructure tours
- Training
 - Various technology trainings (run by vendors)
- Faculty/Staff Development
 - Summer workshops
- Workforce Development
 - Oklahoma IT Mentorship Program



OSCER State of the Center Address
Wed Sep 21 2016



Supercomputing in Plain English

- **FREE and OPEN TO ALL**
- Provided every other spring (upcoming Spring 2016)
- Available LIVE via videoconferencing
- Topics <http://www.oscer.ou.edu/education/>
 1. Overview: What the Heck is Supercomputing?
 2. The Tyranny of the Storage Hierarchy
 3. Instruction Level Parallelism
 4. Stupid Compiler Tricks
 5. Shared Memory Multithreading
 6. Distributed Multiprocessing
 7. Application Types and Parallel Paradigms
 8. Multicore Madness
 9. High Throughput Computing
 10. GPGPU: Number Crunching in Your Graphics Card
 11. Grab Bag: Scientific Libraries, I/O Libraries, Visualization



OSCER State of the Center Address
Wed Sep 21 2016



SiPE Participants

- 362 institutions, firms, agencies and organizations in 51 US states & territories and 17 other countries
 - Academic: 251 institutions in 51 US states & territories and 15 other countries
 - 88 institutions in 26 EPSCoR jurisdictions
 - 16 institutions in Oklahoma
 - Industry: 49 firms in the US and 4 other countries
 - Government: 44 – US federal and state plus 7 other countries
 - Non-Governmental: 18 (US and 1 other country)
- Missing US states & territories
 - EPSCoR states: RI, VT
 - EPSCoR territories: Guam (no PhD-granting)
 - Other territories: American Samoa, Northern Marianas Islands (community colleges only)

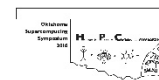

Outreach: Presentations & Tours

■ Courses at OU

1. Chem Engr: Industrial & Environmental Transport Processes (D. Papavassiliou)
2. Engineering Numerical Methods (U. Nollert)
3. Math: Advanced Numerical Methods (R. Landes)
4. Electrical Engr: Computational Bioengineering (T. Ibrahim)

■ Research Experience for Undergraduates at OU

1. Ind Engr: Metrology REU (T. Reed Rhoads)
2. Ind Engr: Human Technology Interaction Center REU (R. Shehab)
3. Meteorology REU (D. Zaras)

■ External

1. American Society of Mechanical Engineers, OKC Chapter
2. Engineering Club of Oklahoma City
3. Association for Computing Machinery (ACM) Special Interest Group on Computer Science Education (SIGCSE) 2010
4. Oklahoma State Chamber of Commerce
5. National Educational Computing Conference 2006 (virtual tour via videoconference)
6. Norman (OK) Lions Club
7. Society for Information Technology & Teacher Education conference 2008, 2009, 2010
8. Axiom Conference on Applied Research in Information Technology 2008
9. Shawnee (OK) Lions Club
10. Oklahoma Louis Stokes Alliance for Minority Participation (@ OSU) 2010 (Keynote)
11. Norman (OK) Science Café
12. Tech Forum Texas 2010
13. Texas Computer Education Association 2011
14. Tinker Air Force Base
15. Consortium for School Networking 2011
16. Consortium for Computing Sciences in Colleges 2011 (Keynote)
17. SC07-13

■ Other Universities

1. SUNY Binghamton (NY)
2. Bradley University (IL)
3. Cameron University (OK)
4. The Citadel (SC)
5. College of the Muscogee Nation (OK)
6. Comanche Nation College (OK)
7. DeVry University (OK)
8. East Central University (OK)
9. El Bosque University (Bogota Colombia)
10. Southwestern University (TX)
11. Langston University (OK)
12. Louisiana State University
13. Midwestern State University (TX)
14. Northeastern Oklahoma State University
15. Northwestern Oklahoma State University
16. Oklahoma Baptist University
17. Oklahoma City University
18. Oklahoma State University x 2
19. Oklahoma State University – OKC
20. Oral Roberts University (OK) x 2
21. Rogers State U (OK)
22. Philander Smith College (AR)
23. St. Gregory's University (OK) x 2
24. Southeastern Oklahoma State University x 2
25. Southern Nazarene University (OK)
26. Southwestern Oklahoma State University x 2
27. Texas A&M-Commerce
28. University of Arkansas Fayetteville
29. University of Arkansas at Little Rock
30. University of Arkansas at Pine Bluff
31. University of Central Oklahoma
32. University of Oklahoma-Tulsa
33. University of Science & Arts of Oklahoma
34. University of Texas Brownsville
35. University of Tulsa (OK)

■ High Schools and High School Programs

1. Oklahoma School of Science & Mathematics x 2
2. Oklahoma Christian University's Opportunity Bytes Summer Academy
3. Dept of Energy National Scholarship Finalists
4. Ardmore High School (OK)
5. Elgin Middle School



OSCER State of the Center Address
Wed Sep 21 2016

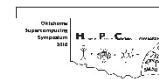

Fac/Staff Dev: Summer Workshops

- National Computational Science Institute workshops
 - Intro to Parallel Programming & Cluster Computing weeklong: summer 2004, summer 2005, summer 2008, summer 2009, summer 2012
 - Intro to Parallel Programming & Cluster Computing daylong: fall 2003, fall 2007-11
 - Intermediate Parallel Programming & Cluster Computing weeklong: summer 2010, summer 2011
 - LittleFe baby supercomputer buildout (summer 2011 – first ever anywhere; summer 2012)
 - Computational Chemistry for Chemistry Educators weeklong: summer 2009, summer 2011
 - Many of these were co-sponsored by Oklahoma EPSCoR (2008-2012) and/or the SC Education Program (2007-9, 2011)



OSCER State of the Center Address
Wed Sep 21 2016



Fac/Staff Dev: Summer Workshops

- Linux Clusters Institute workshops: June 2005, Feb 2007
 - Selected to host the next LCI workshop (2016)
- Virtual School for Computational Science & Engineering weeklong
 - 2012: Programming Heterogeneous Parallel Computing Systems; Proven Algorithmic Techniques for Many-core Processors (both on GPU computing)
 - 2013, 2016: Data Intensive Summer School (big data)
- Software Carpentry Bootcamp (2013): Python, scripting, version control etc
- Bioinformatics weeklong (2012, 2016)
- **SUMMARY: Every summer 2004-2016 except 2006, 2007.**



OSCAR State of the Center Address
Wed Sep 21 2016



OK IT Mentorship Program

The Oklahoma Information Technology Mentorship Program is sending networking professionals to universities, colleges, career techs and even a high school statewide.

These professionals will give talks on the practicalities of being a networking professional – what that career choice means day by day.

We also provide both live and virtual job shadowing opportunities – students can follow networking professionals around to see what their work looks like, either in person or via Twitter and Facebook.

So far we've done over 100 events for 39 institutions.



OSCAR State of the Center Address
Wed Sep 21 2016



OneOklahoma
Cyberinfrastructure
Initiative
2013-18

OneOklahoma Cyberinfrastructure Initiative

• OPSU

• NWOSU

• RSU

2013-18

Resource Providers: OU, OSU, TSC, Langston (HBCU, HEP)

- All OCII Services
- Informatics: Research facilitators (NOT researchers) who embed in specific research teams . Expands Informatics team from just OU to OSU, available to others statewide.
- cyberCommons: adaptable Big Data environment developed under OK-KS Track-2 (2009-13).
- Data Stewardship Initiative: collaboration among CI and Libraries.
- OK STEM Mentorship Program: extended OK IT Mentorship Program to other STEM disciplines.

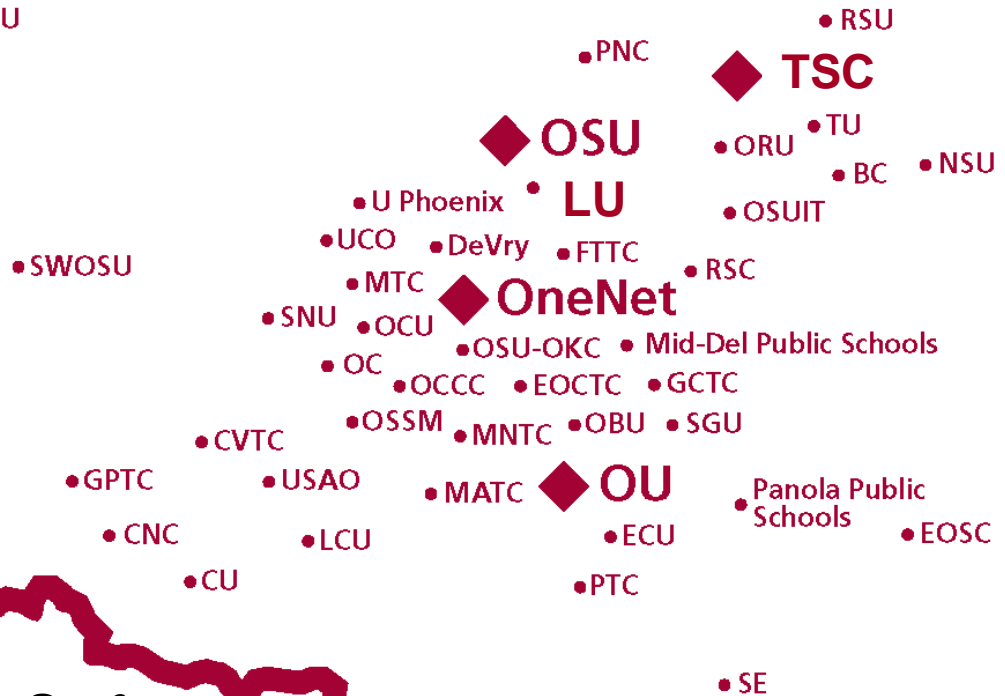

So far:
52 OK academic
48 OK non-academic



OSCER State of the Center Address
 Wed Sep 21 2016

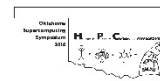

NEW! OneOCII

All of OCII, plus:

- Informatics professionals: research facilitators embedded in specific research projects (and largely funded by them)
- CyberCommons (from old NSF EPSCoR RII Track-2 grant)
 - Software platform for end-to-end research workflow support
- Physical resources
 - Research Cloud: research teams can buy virtual servers
 - Hadoop cluster
- Data Stewardship Initiative (led by Libraries)
- Oklahoma STEM Mentorship Program (not just IT) – already 20 institutions signed up, including 3 new



OSCER State of the Center Address
Wed Sep 21 2016

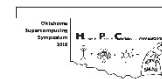

NSF EPSCoR RII Track-1

- “Adapting Socio-ecological Systems to Increased Climate Variability”
- OU, OSU, U Tulsa, Noble Foundation
- \$24M (\$20M NSF, \$4M State Regents) over 5 years
- Includes just under \$1M for Informatics
 - OU: heavy in Year 1 and first half of Year 2, light thereafter
 - OSU: nothing in Year 1 and first half of Year 2, 1 FTE thereafter
 - Sustainability plan, in place, guarantees at least through 2021



OSCER State of the Center Address
Wed Sep 21 2016



OneOCII HPC

Over 200 TFLOPs of HPC capacity across the state
(5X increase from 2008-12)

- OU: 110.6 TFLOPs, acquired 2012 (internally funded)
- OSU: 48.8 TFLOPs, acquired 2012 (NSF MRI)
- Langston U: 8 TFLOPs CPU, 18.72 TFLOPs GPU, acquired 2013 (NSF MRI)
- Tandy Supercomputing Center (Tulsa): 34.56 TFLOPs, acquired 2013 (independently of OCII/OneOCII)
- UCO: 30+ TFLOPs



OSCER State of the Center Address
Wed Sep 21 2016



OK STEM Mentorship Program

- Already have presenters signed up for:
 - Agriculture
 - Earth Sciences
 - Atmospheric Sciences: Meteorology
 - Ecological Sciences: Ecology, Rangeland Ecology, Urban Ecology
 - Geographical Sciences: Geography, Geographic Information Systems
 - Engineering: IT/CS
 - Libraries
 - Life Sciences: Plant Biology
 - Social Sciences: Anthropology, Economics, Political Science



OSCAR State of the Center Address
Wed Sep 21 2016



Acknowledgements

Portions of this material are based upon work supported by the National Science Foundation under the following grants:

- Grant No. EPS-0814361, “Building Oklahoma's Leadership Role in Cellulosic Bioenergy”
- Grant No. EPS-1006919, “Oklahoma Optical Initiative”
- Grant No. OCI-1039829, “MRI: Acquisition of Extensible Petascale Storage for Data Intensive Research”
- Grant No. OCI-1126330, “Acquisition of a High Performance Compute Cluster for Multidisciplinary Research”
- Grant No. ACI- 1229107, “Acquisition of a High Performance Computing Cluster for Research and Education”
- Grant No. EPS-1301789, “Adapting Socio-ecological Systems to Increased Climate Variability”
- Grant No. ACI-1341028, “OneOklahoma Friction Free Network”
- Grant No. ACI-1429702, “Acquisition of a High Performance Computing Cluster for Research at a Predominantly Undergraduate Institution”
- Grant No. ACI-1440774, “Leveraging Partnerships Across the Great Plains to Build Advanced Networking and CI Expertise”
- Grant No. ACI-1440783, “A Model for Advanced Cyberinfrastructure Research and Education Facilitators”



OSCER State of the Center Address
Wed Sep 21 2016



Acknowledgements

Dell provided seed systems for the OU Research Cloud (“OURcloud”) and the OU Science DMZ.



OSCER State of the Center Address
Wed Sep 21 2016

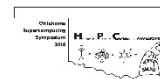

Symposium 2016 Sponsors: Thank You!

- Academic sponsor (1)
 - Great Plains Network
- Industry sponsors (17/18)
 - Platinum (1): Intel + HP
 - Gold (7): Arista Networks, **Brocade**/Lumenate, Dell, Mellanox Technologies, NVIDIA, **Quantum**, **Qumulo**
 - Silver (4): Cray, DataDirect Networks, SGI, Spectra Logic
 - Bronze (5/6): Adaptive Computing, Advanced Clustering Technologies, Aspen Systems, **Penguin**, **Pinnacle**/EMC

Thank you all! Without you, the Symposium couldn't happen. Over the past 14 Symposia, we've had a total of 84 companies as sponsors – and more than half have repeated (or were acquired by/merged with other sponsors).



OSCER State of the Center Address
Wed Sep 21 2016



Thanks!

- OU IT
 - OU CIO/VPIT Loretta Early
 - Symposium committee: Josh Alexander (OU), Dana Brunson (OSU), Debi Gentis (OU), George Louthan (OII), Franklin Fondjo Fotou (LU), Joel Snow (LU), Karl Frinkle (SE), Evan Lemley (UCO)
 - Symposium coordinator: Debi Gentis
 - Sponsorship coordinator: Chance Grubb
 - OSCER Operations Team: Dave Akin, Brett Zimmerman, Josh Alexander, Patrick Calhoun
 - All of the OU IT folks who helped put this together
- CCE Forum
 - Jake Maurer, Kristin Livingston
 - The whole Forum crew who helped put this together



OSCER State of the Center Address
Wed Sep 21 2016

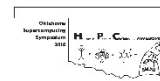

Thanks: Plenary Speakers

- Jim Kurose, NSF Computer & Information Science & Engineering Directorate
- Carl Grant (OU), Adrian Alexander (TU), Jennifer Fitzgerald (Noble), Mark Laufersweiler (OU), Robin Leech (OSU), Habib Tabatabai (UCO)
- Monica Martinez-Canales, Intel & Stephen Wheat, HP (Platinum sponsors)



OSCAR State of the Center Address
Wed Sep 21 2016



Thanks: Gold Sponsor Speakers

- Mickey Stewart, Arista Networks
- Dan DeBacker, Brocade Communications Systems Inc.
- DJ Spry, Dell
- Kashif Chauhan & D. Kent Snider, Mellanox Technologies
- Bob Crovella, NVIDIA
- Neal Wingenbach, Quantum
- Bob Collins, Qumulo



OSCER State of the Center Address
Wed Sep 21 2016



Thanks: Breakout Speakers

1. Kate Adams, GPN
2. Dan Andresen, KSU
3. Joseph Babb, Tinker AFB
4. Dana Brunson, OSU
5. Eduardo Colmenares, MWSU
6. Nick Davis, OU Tulsa
7. Jim Ferguson, NICS
8. Karl Frinkle & Mike Morris, SEOSU
9. John Hale, Peter Hawrylak, Andrew Kongs, TU
10. Utkarsh Kapoor, OSU
11. Scott Lathrop, XSEDE/Shodor
12. David Monismith
13. Mukundhan Selvam, WSU
14. Dan Stanzione, TACC



OSCAR State of the Center Address
Wed Sep 21 2016



Thanks!

To all of you for participating, and to those many of you who've shown us so much loyalty over the past 14 years.



OSCAR State of the Center Address
Wed Sep 21 2016



Such a bargain!

- If you want your t-shirt and your power bank, all you have to do is give us a completed evaluation form!
- It's that easy!
- What a bargain!



OSCER State of the Center Address
Wed Sep 21 2016



To Learn More

<http://www.oscer.ou.edu/>

<http://oneocii.okeyscores.org/>



OSCER State of the Center Address
Wed Sep 21 2016

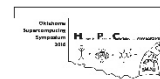

**Thanks for your
attention!**

Questions?

OneOklahoma
Friction Free
Network
2013-15

NSF CC-NIE Grant

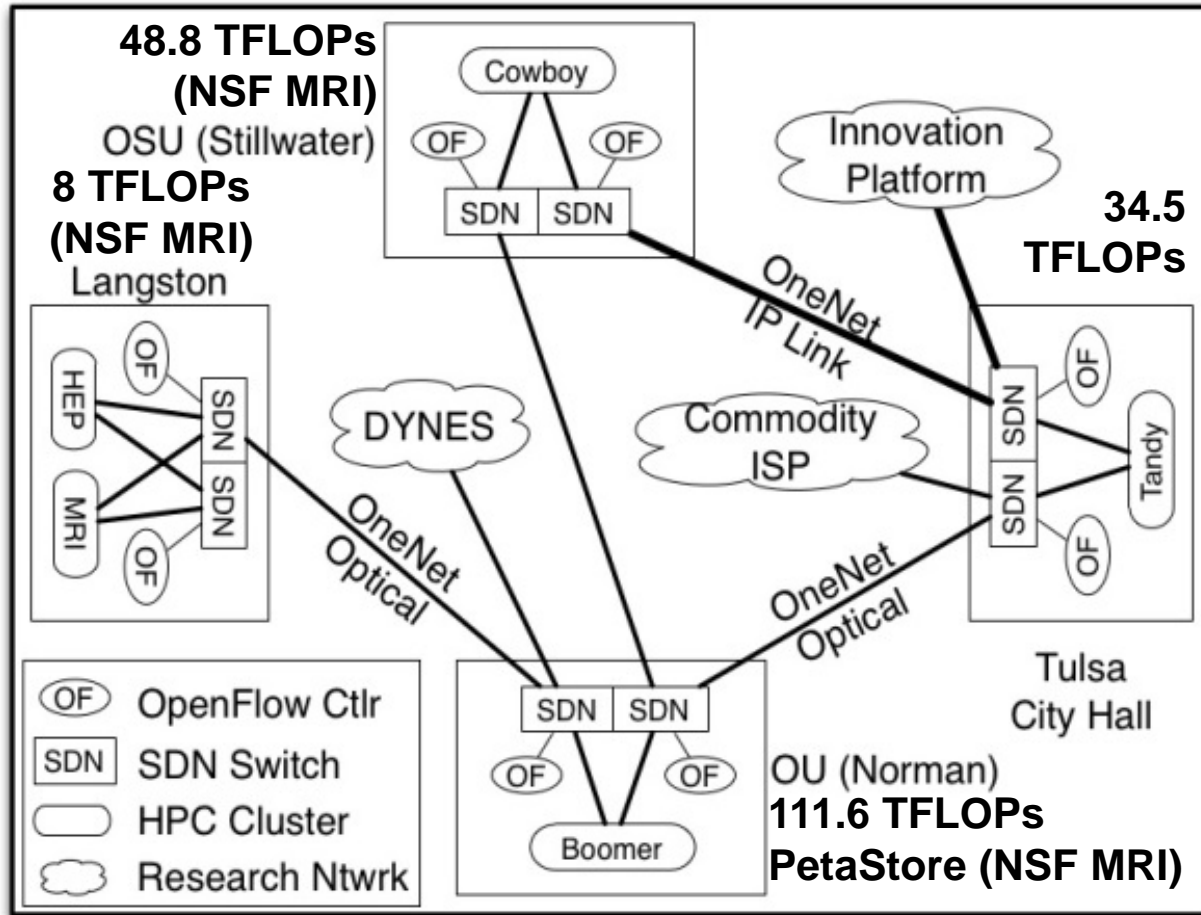

OneOklahoma Friction Free Network (OFFN)

- Multi-institutional Science DMZ
- Software Defined Networking
- Dedicated 10G among the participating sites
- Aggregate compute: just over 200 TFLOPs (peak)

Objectives

1. Deploy and maintain, at the four institutions, a research-only network consisting of institutional last mile components that are independent of enterprise networks, with its internal hub collocated with OneNet.
2. Apply Software Defined Networking (SDN) across OFFN, facilitating end-to-end management, by researchers, of high bandwidth/high performance data flows through a distributed hierarchy of open standards tools, giving researchers a new layer of transparency into network transport.
3. Provide these capabilities – OFFN's in particular and OneOCII's in general – to all relevant researchers and educators statewide, and facilitate their use.



OSCER State of the Center Address
Wed Sep 21 2016



Initial Science Drivers

- High Energy Physics (ATLAS, DØ): OU, LU, OSU
- Real Time Numerical Weather Prediction: OU
- Weather Radar: OU
- Bioinformatics: OSU
- Ecological Informatics: OU (added after grant started)
- ... with more to come.

Identified aggregate bandwidth: 23+ Gbps (when everything is going full tilt at the same time)



OSCER State of the Center Address
Wed Sep 21 2016



Science Driver: High Energy Physics

- Senior Personnel
 - H. Severini (OU)
 - P. Skubic (OU)
 - J. Snow (LU)
 - M. Strauss (OU)
- Oklahoma Center for High Energy Physics (OCHEP)
- Funding: \$1.7M current, \$1M planned (NSF, DOE, Fermilab)
- 7 faculty, 2 staff, 4 postdocs, 3 graduate students
- Identified bandwidth need: up to 8 Gbps sustained



OSCER State of the Center Address
Wed Sep 21 2016

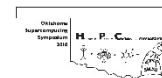

Science Driver: High Energy Physics

- OU and LU already do a lot of ATLAS computing (data analysis and Monte Carlo simulation).
- OU, LU and OSU constitute the Oklahoma Center for High Energy Physics (OCHEP).
 - OSU physicists aren't doing computational.
- OU, LU and U Texas Arlington constitute the NSF's ATLAS Southwest Tier2 Center (SWT2), which is consistently in the top 3 most productive US academic Tier2 sites (OU is consistently #6-#8 most productive US academic institution).
- OSU and TSC have agreed to provide their idle cycles for ATLAS jobs, but will kill them off in favor of local jobs.



OSCER State of the Center Address
Wed Sep 21 2016



Science Driver: Weather Prediction

- OU Center for Analysis & Prediction of Storms (CAPS)
- Senior Personnel
 - M. Xue (CAPS Director and faculty in OU's School of Meteorology)
 - K. Brewster (CAPS Associate Director)
- Funding: \$2.5M per year current, \$1M per year planned (NSF, NOAA)
- 6 faculty, 10 staff, 20 graduate students
- Identified bandwidth need: 12 Gbps sustained (during the annual Spring Realtime Storm Forecasting Experiment, mid-March – mid-June)



OSCER State of the Center Address
Wed Sep 21 2016



Science Driver: Weather Radar

- Advanced Radar Research Center (ARRC)
- Senior Personnel: Tian-You Yu et al
- Funding: \$10M current, \$5M pending, \$25M planned (NOAA, NSF, NASA, industry)
- 15 faculty, 2 staff, 11 postdocs, ~60 graduate students, ~10 undergraduates
- Identified bandwidth need: 1.9 Gbps sustained



OSCER State of the Center Address
Wed Sep 21 2016



Science Driver: Bioinformatics

- OSU Bioinformatics program
- Senior Personnel Elshahed (OSU), Hoyt (OSU)
- Funding: \$6.1M current, \$4.4M pending (NSF, NIH, USDA, DOD, US Army, OCAST, OK Ag Experiment Station)
- 14 faculty, 6 postdocs, 35 graduate students
- Identified bandwidth need: likely 1.6+ Gbps – lesser of (a) bandwidth of OSU HPC cluster disk or (b) bandwidth of Oklahoma PetaStore disk



OSCER State of the Center Address
Wed Sep 21 2016



Network Deployment Goals

- Provide a proven, commercial off-the-shelf (COTS) hardware platform backed with vendor support.
- Realize the Science DMZ goals through the use of a truly independent network at each campus site.
 - The network deployment will consist of dedicated optical pathways to the optical transport provider (OneNet), as well as to the local campus backbone where desired.
- Deploy a fully virtualized infrastructure, to be used simultaneously by multiple research entities, presented to each entity as a dedicated “slice” of the overall resource.
- Leverage federation to provide oversight and visibility into the operations of the virtualized platform.



OSCER State of the Center Address
Wed Sep 21 2016



Network Deployment Goals (cont'd)

- Realize the full potential of OFFN through awareness, training, site-specific hand-off, and communities of support for OFFN adopters.



OSCER State of the Center Address
Wed Sep 21 2016



State Diagram (Conceptual)



OSCER State of the Center Address
Wed Sep 21 2016



State Diagram (Logical)

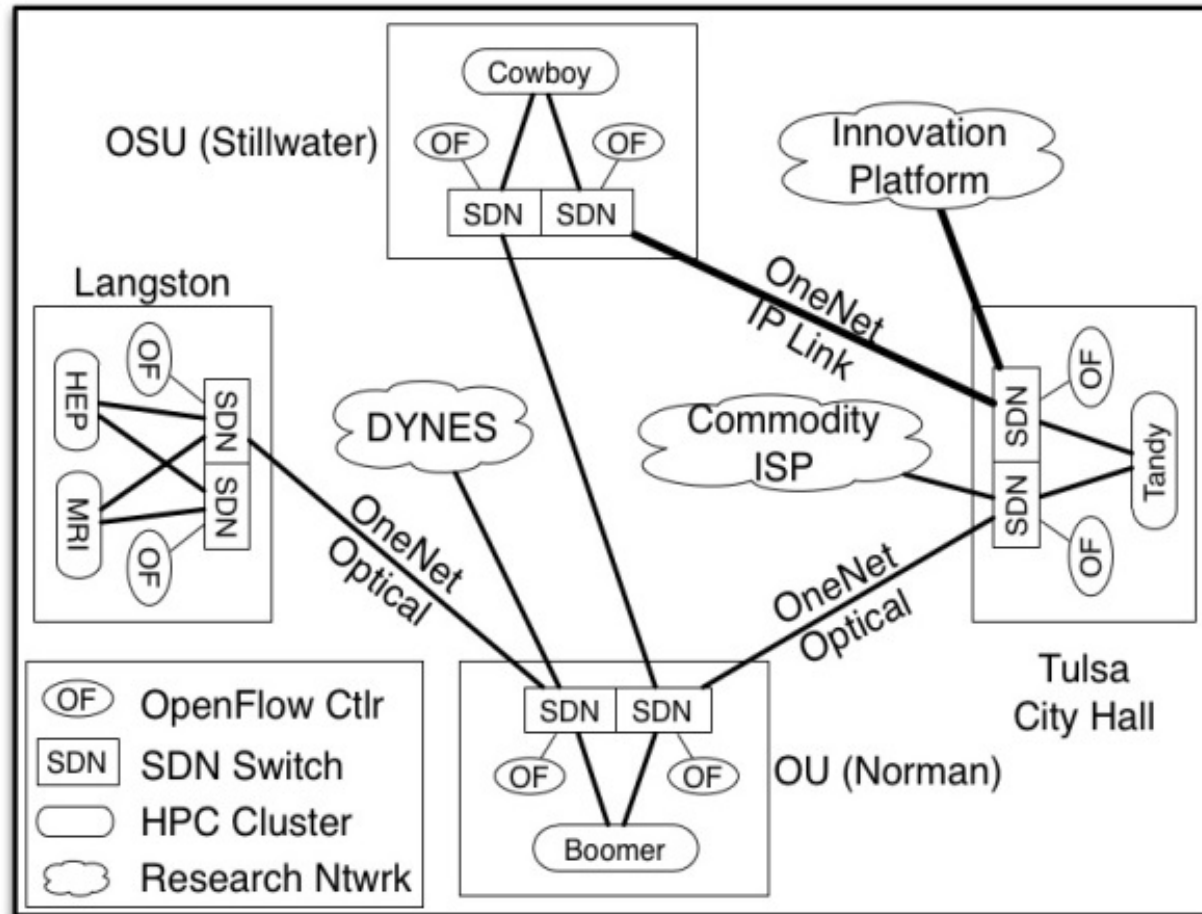

Institutional Design

- SDN switches provide a virtualized data plane resource, to effectively and efficiently forward Ethernet traffic based on rules configured on the SDN controller. (Note that TSC will use a 24-port SDN-capable Brocade linecard instead.)
- Platform support switches provide the connectivity required for out-of-band management functions, including server lights-out management, SDN switch component management, and Virtual Machine (VM) host management.



OSCER State of the Center Address
Wed Sep 21 2016



Institutional Design (cont'd)

- Servers provide multiple virtualized SDN controller resources, plus a virtualized platform for providing performance toolsets, management and monitoring utilities, and data transfer tools (e.g., perfSonar).
- Software (all Open Source and/or free)
 - OS virtualization platform (Xen, VirtualBox or Qemu)
 - Linux host and guest OS (Fedora or CentOS)
 - SDN controller (Beacon or Floodlight)
 - Performance testing (iPerf and the PSPPerformance Toolkit)
 - Monitoring (Cacti or Nagios)

Institutional Diagram (Logical)

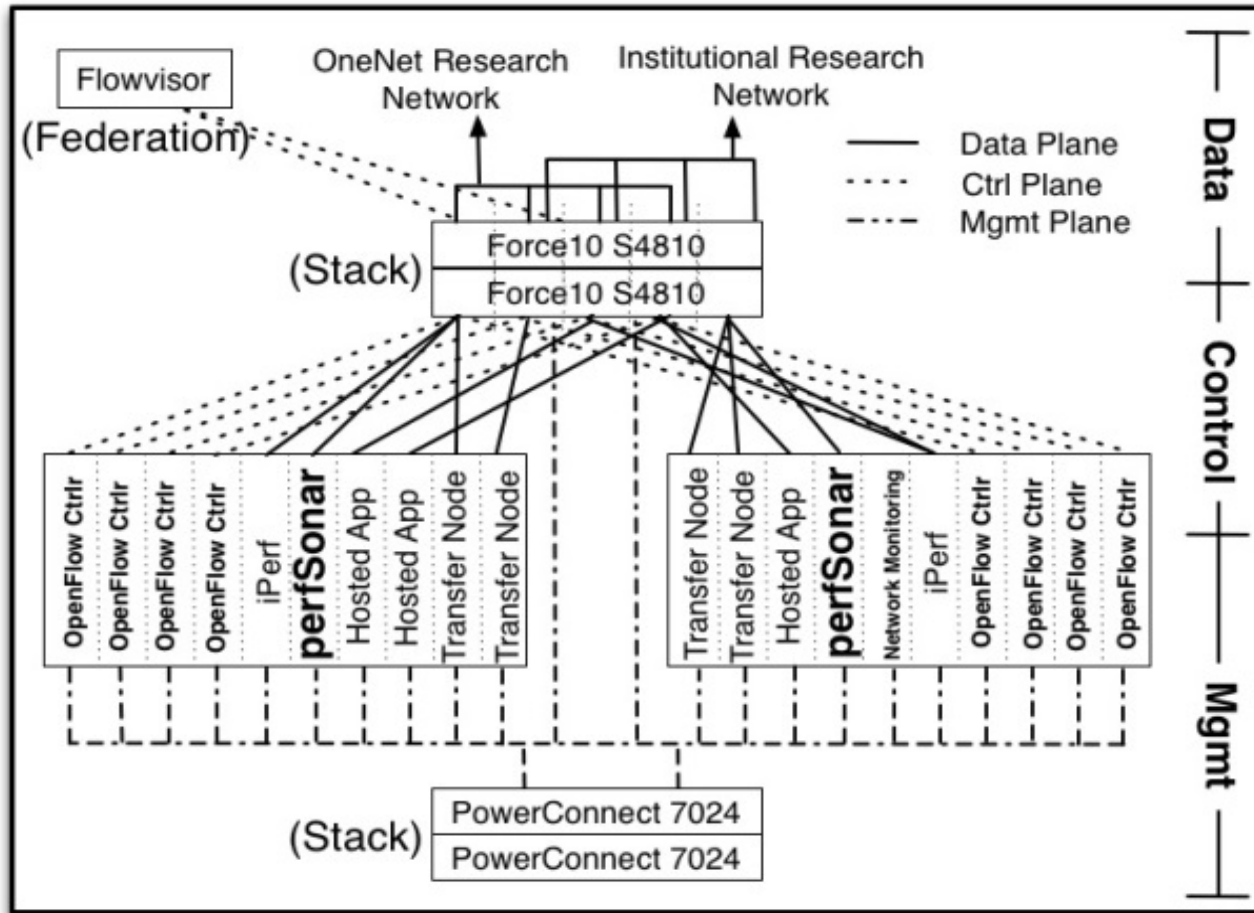

Institutional Diagram (Physical)

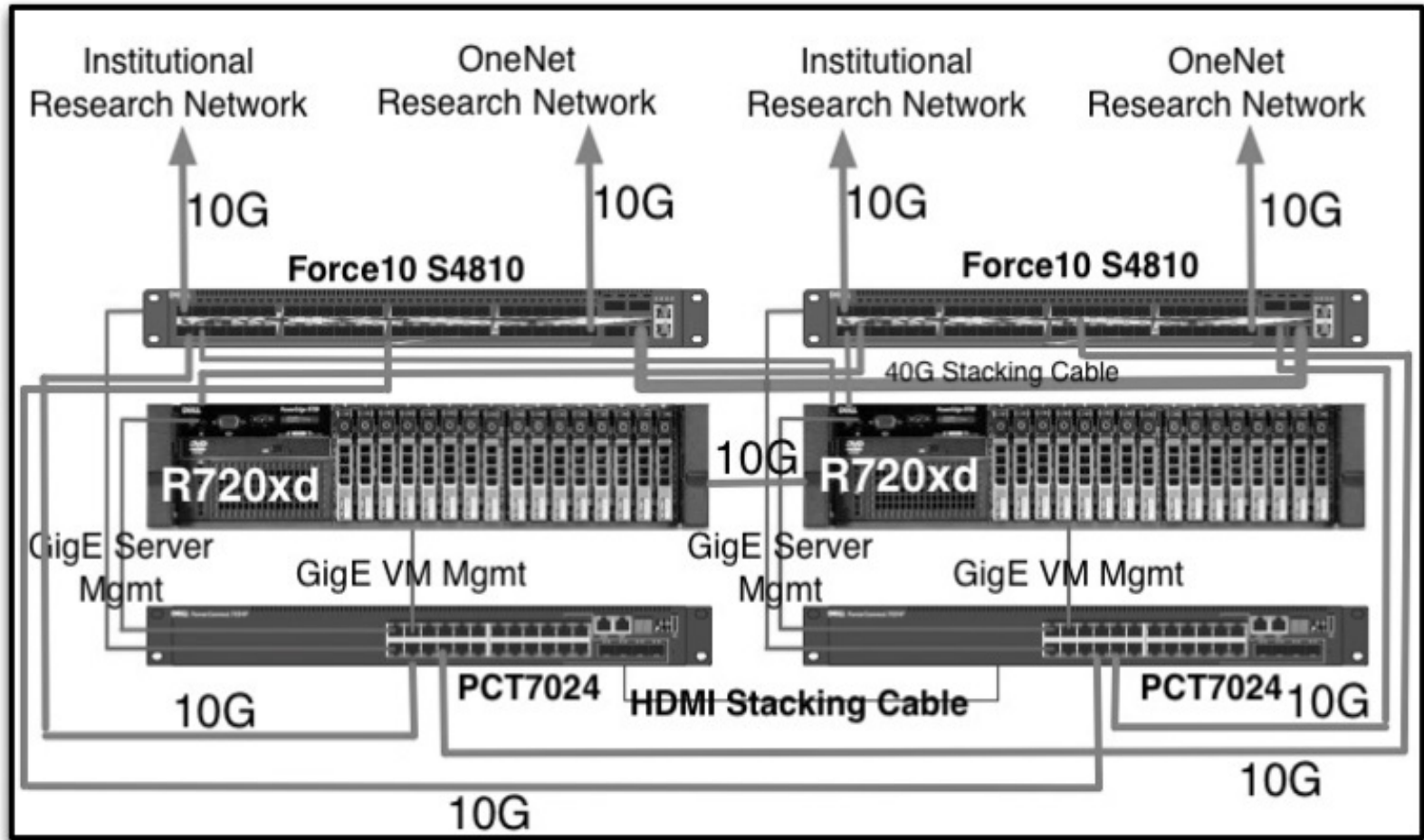

External Connectors

- **Innovation Platform**: OneNet has secured a 100G connection onto Internet2's Innovation Platform (IP).
 - OSU has dedicated connectivity to connect to the IP at 100G.
 - OU is deploying 2 x 10G with Layer-2 and Layer-3 transport services, from OU to OneNet, connecting directly into the same OneNet chassis as the IP. Under OFFN, researchers statewide will straightforwardly be able to access the IP via OU and OSU.
- **DYNES**: OU hosts a “static” DYNES site deployment.
 - Primarily implemented as a dedicated path tool for OUHEP's SWT2 cluster to receive large datasets from LHCOne.
 - Can easily be migrated to the 4PP Science DMZ.



External Connectors (cont'd)

- **XSEDE**: OU's already-funded plan to connect to the Innovation Platform can also facilitate connection to XSEDEnet at no additional charge, by OneNet simply setting aside 10 Gbps of the 100 Gbps connection into the Innovation Platform (subject to OneNet's and XSEDE's approval).
- **PlanetLab** provides an overlay services network that can be decomposed into tangible resource pools used for network experimentation. Both OU and OSU provide dedicated PlanetLab hardware resources.